

**OWNER'S MANUAL**  
**MODEL GT**  
**LOGIC CONTROL (VER. 2.0)**  
**INDUSTRIAL DUTY DOOR OPERATOR**

**LOGIC CONTROL**

**L**

FACTORY SET

**C2 Wiring**

See pages 14 and 15  
for other wiring  
configurations

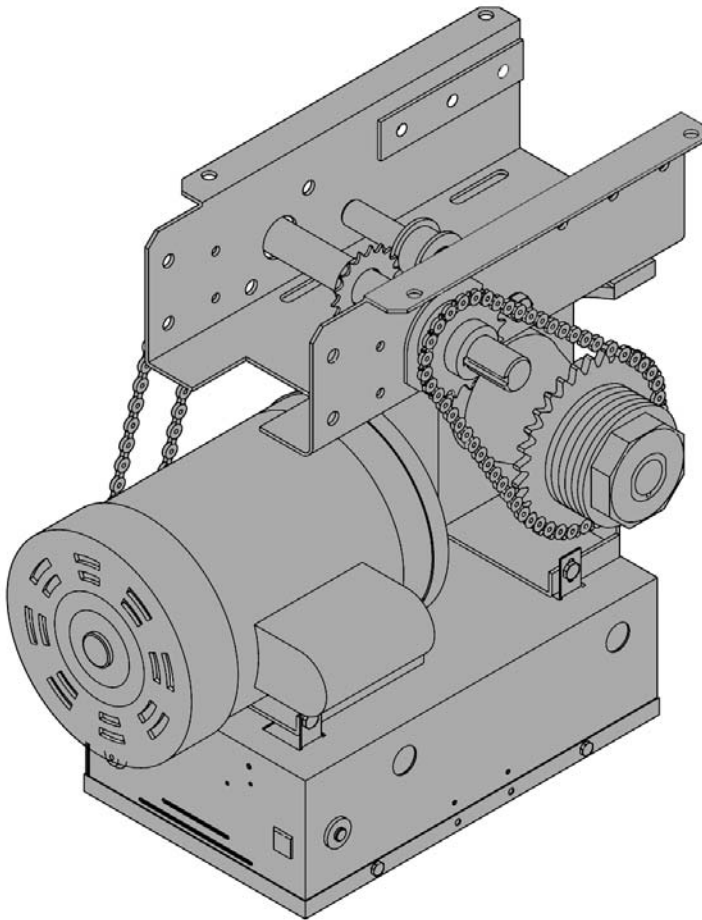

**This Opener Features**



**Maintenance Alert System**

PATENT PENDING

The Maintenance Alert System™ allows the installer to set an internal Maintenance Cycle Counter. An LED on the 3-button station will signal when the set number of cycles is reached or when the opener requires immediate service.

**2 YEAR WARRANTY**

Serial # \_\_\_\_\_  
(located on electrical box cover)

Installation Date \_\_\_\_\_

Wiring Type \_\_\_\_\_

**NOT FOR RESIDENTIAL USE**





Before attempting to install, operate or maintain the operator, you must read and fully understand this manual and follow all safety instructions.



These instructions are intended to highlight certain safety related issues. These instructions are not intended to be comprehensive. Because each application is unique, it is the responsibility of the purchaser, designer, installer and end user to ensure that the total door system is safe for its intended use.

## TABLE OF CONTENTS

<b><u>SPECIFICATIONS</u></b>	
Packing List . . . . .	2
Motor Specification . . . . .	3
Electrical Specifications . . . . .	3
Mechanical Specifications . . . . .	3
Safety Specifications . . . . .	3
Weights & Dimensions . . . . .	3
<b><u>PREPARATION</u></b>	
Track Assembly . . . . .	4
Powerhead Attachment . . . . .	4
Trolley Carriage/Chain Attachment . . . . .	5
<b><u>INSTALLATION INSTRUCTIONS</u></b>	
Header Bracket . . . . .	5
Operator Mounting . . . . .	5
Operator Support . . . . .	6
Straight Arm . . . . .	6
<b><u>ENTRAPMENT PROTECTION ACCESSORIES</u></b>	
Sensing Edges & Photo Eyes . . . . .	7
<b><u>LIMIT SWITCH ADJUSTMENT</u></b>	
Limit Location . . . . .	7
Adjustment . . . . .	7
<b><u>POWER &amp; CONTROL WIRING</u></b>	
Safety Warnings . . . . .	8
Power Wiring . . . . .	9
Ground Wiring . . . . .	9
Control Station Wiring . . . . .	9
Radio Controls . . . . .	9
Mounting Instructions . . . . .	9
Optional Control Mounting . . . . .	9
Optional Control Wiring . . . . .	28
Emergency Disconnect System . . . . .	10
Torque Adjustment . . . . .	10
<b><u>BRAKE ADJUSTMENT</u></b>	
Brake Parts . . . . .	10
<b><u>WIRING DIAGRAMS</u></b>	
1 PH Wiring . . . . .	11
3 PH Wiring . . . . .	12
1 PH Wiring w/Contactor . . . . .	13
<b><u>STANDARD PROGRAMMING</u></b>	
Wiring Type . . . . .	14 & 15
RPM Sensor . . . . .	16
Maximum Run Timer . . . . .	16
Maintenance Alert System . . . . .	17
<b><u>OPTIONAL PROGRAMMING</u></b>	
Mid Stop . . . . .	17
Timer to Close . . . . .	18
Red Green Warning Lights . . . . .	18
Board Illustration . . . . .	19
<b><u>REPLACEMENT PARTS &amp; MAINTENANCE</u></b>	
Trouble Shooting Guide . . . . .	20 & 21
Maintenance Schedule . . . . .	22
Customer Service Contact Information . . . . .	22
Electrical Box parts . . . . .	23 & 24
Chassis Parts (J) . . . . .	25 & 26

## PACKING LIST

Before beginning your installation check that all components were supplied and received undamaged.

<b>PACKING LIST K77-14815</b>		
<b><u>PART #</u></b>	<b><u>DESCRIPTION</u></b>	<b><u>QTY</u></b>
02-103L	3 BUTTON CONTROL STATION	1
10-10203	CURVED DOOR ARM	1
10-10204	DOOR BRACKET	1
10-10205	TRACK END BRACKET	1
77-10200	HARDWARE BAG	1
75-10259	TRACK SPACER ASSY.	1
75-17942	TROLLEY SLIDER	1

# SPECIFICATIONS

## MOTOR

**TYPE:** .....Continuous duty  
**HORSEPOWER:**.....1/2, 3/4, 1 & 1-1/2 Hp  
**SPEED:**.....1725 RPM  
**VOLTAGE:** .....115, 208-230 Single phase  
 230, 380, 460, 575 Three phase  
**CURRENT:** .....See motor nameplate

## ELECTRICAL

**TRANSFORMER:**.....24VAC  
**CONTROL STATION:**.....NEMA 1 three button station.  
 OPEN/CLOSE/STOP W/ LED  
**WIRING TYPE:** .....C2 (Factory Shipped)  
 Momentary contact to OPEN & STOP, constant pressure to CLOSE, open override plus wiring for sensing device to reverse. See pages 14 and 15 for optional wiring types and operating modes.  
**LIMIT ADJUST:**.....Linear driven, fully adjustable screw type cams. Adjustable to 24 feet.

## MECHANICAL

**DRIVE REDUCTION:**.....Primary: Heavy duty wormgear-in-oil-bath speed reducer.  
**OUTPUT SHAFT SPEED:**.....64 R.P.M.  
**DOOR SPEED:**.....1 Foot per sec.  
 depending on door  
**BRAKE:** .....Solenoid actuated disc brake.  
**BEARINGS:** .....Output Shaft: Shielded Ball Bearing.

## SAFETY

**DISCONNECT:** .....Quick disconnect door arm for emergency manual door operation.  
**SAFETY PHOTO EYES:** (Optional) Thru beam or retro reflective devices used to provide non-contact safety protection. Directly interface to Lift Master CPS-L or CPS-LN4 Commercial Protector Systems.  
**SAFETY EDGE:** .....(Optional) Electric or pneumatic sensing device attached to the bottom edge of door.  
**A REVERSING DEVICE IS STRONGLY RECOMMENDED FOR ALL COMMERCIAL OPERATOR INSTALLATIONS. REQUIRED WHEN THE 3 BUTTON CONTROL STATION IS OUT OF SIGHT OF DOOR OR ANY OTHER CONTROL (AUTOMATIC OR MANUAL) IS USED.**

## WEIGHTS AND DIMENSIONS

**HANGING WEIGHT:** .....110-140 LBS.

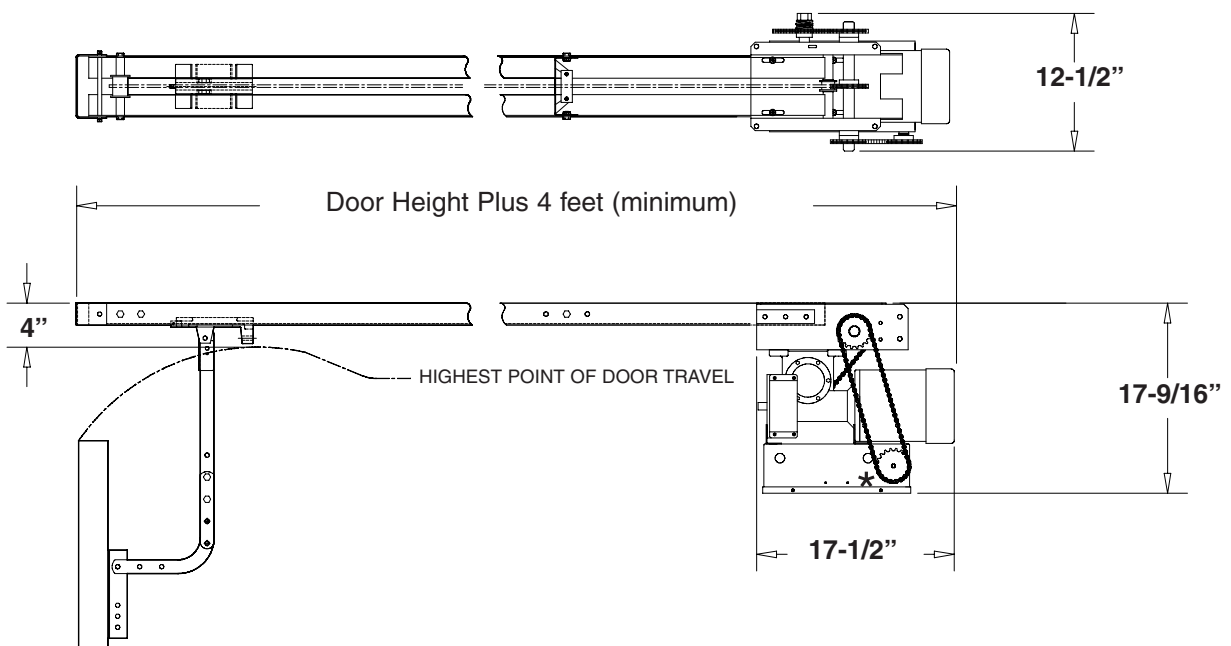

# OPERATOR PREPARATION



## WARNING

KEEP DOOR BALANCED. STICKING OR BINDING DOORS MUST BE REPAIRED. DOORS, DOOR SPRINGS, CABLES, PULLEYS, BRACKETS AND THEIR HARDWARE MAY BE UNDER EXTREME TENSION AND CAN CAUSE SERIOUS PERSONAL INJURY OR DEATH. CALL A PROFESSIONAL DOOR SERVICEMAN TO MOVE OR ADJUST DOOR SPRINGS OR HARDWARE.

### TRACK ASSEMBLY

1. Using the 3/8"-16 x 3/4" bolts and flange hex nuts supplied, assemble the operator track by installing and tightening the track spacer brackets. Position the spacers evenly over the length of the track. NOTE: The nylon pad on the spacer bracket should face up.
2. Using (2) 3/8"-16 x 1" bolts and lock washers, install the front idler assembly to the second set of holes of one end of the track. Refer to the illustration below.
3. Slide the trolley carriage onto the track so that the take-up bolt will be toward the operator.

### POWERHEAD ATTACHMENT

1. Position the track assembly on the frame of the powerhead so that the motor side of operator is in back (away from door).
2. Secure the operator in place by installing six 3/8"-16 x 3/4" bolts in the three holes on each side of the frame and track.

4. Connect the track to the powerhead by fastening two 3/8"-16 x 3/4" bolts and nuts through the frame and the end holes in track. Tighten all four bolts to secure the track to the powerhead.

### TROLLEY CARRIAGE / CHAIN ATTACHMENT

1. Attach the take-up bolt to the trolley carriage using 3/8-16 hex nuts and lock washer, as shown below.
2. Using one of the master links, attach the chain to the other end of the trolley carriage. Reel the chain around the front idler shaft, over the spacer brackets, back to the drive shaft sprocket, and then to the take-up bolt on the carriage.
3. Using the other master link, attach the chain to the take-up bolt and tighten to the desired chain tension.

**CHAIN TENSION:** With trolley positioned at either end of the track, a properly adjusted chain will sag about 3" at the mid-point. If necessary, remove links from the chain to achieve proper adjustment.

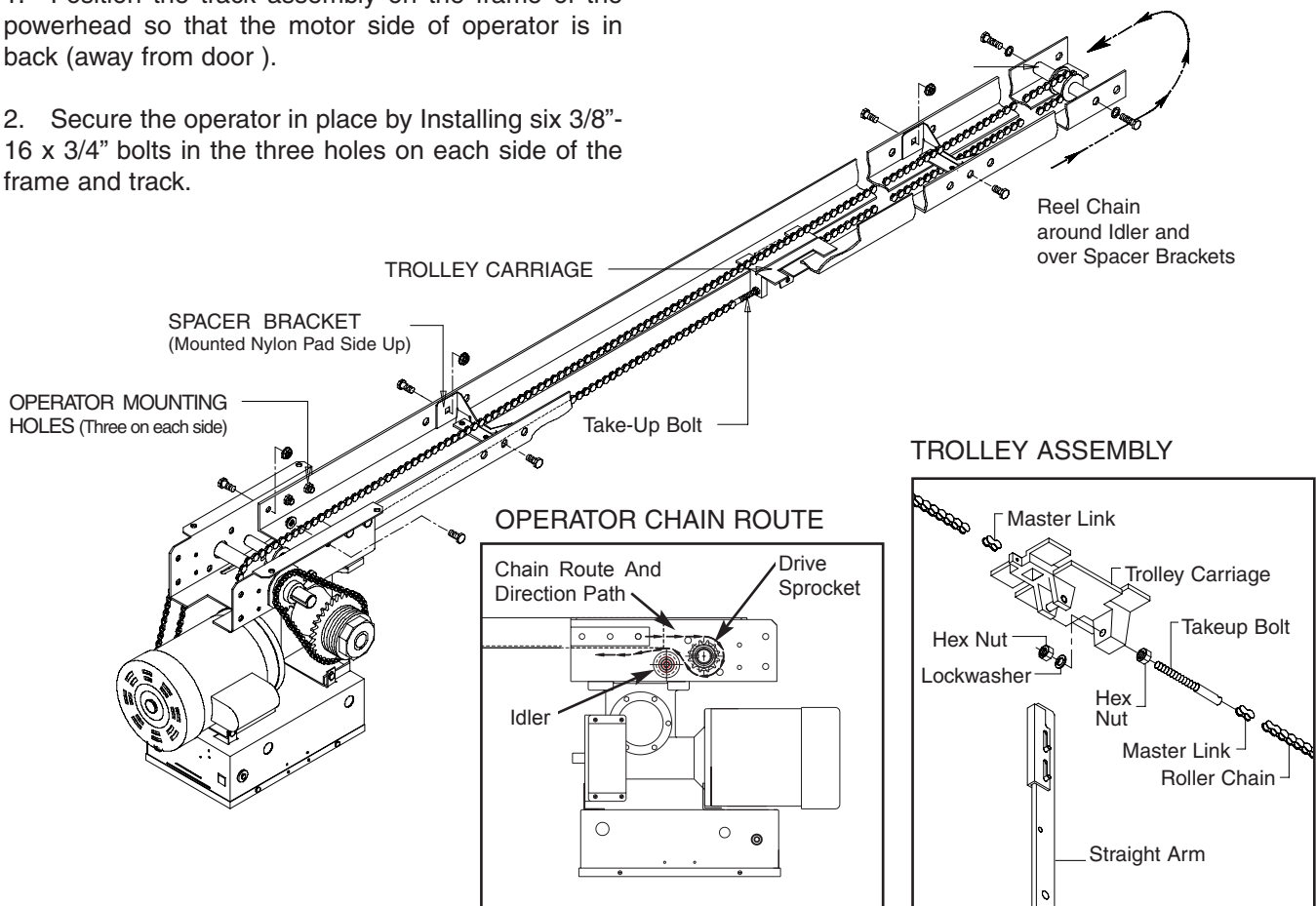

# INSTALLATION INSTRUCTIONS

**IMPORTANT NOTE:** Before the operator is installed, be sure the door has been properly aligned and is working smoothly. Although each installation will vary due to particular building characteristics, refer to the following general procedures to install the operator.

## MOUNT HEADER BRACKET

The trolley operator is generally mounted over the center of the door. However, off center mounting may be required due to interfering structures or location of door stile / top section support. In such cases, the operator may be mounted up to 24" off center on torsion spring doors. Extension springs require center mounting.

1. Locate the center of the door and mark a line on the wall directly above the door. Extend this line up the wall.
2. Determine the highest point of door travel. Slowly raise the door and observe the action of the top section. When the top section reaches its highest point, use a level and project a line from this point to the center line of the door.

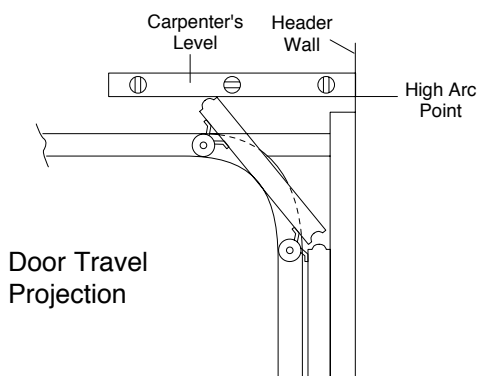

3. Using the projected lines for location, mount a suitable wood block or length of angle iron to the wall above the door opening. Refer to the illustration below. This will provide a mounting pad for the front header bracket of the operator. If necessary reinforce the wall with suitable mounting brackets to ensure adequate support of mounting pad. Using suitable hardware, mount the (U shaped) front header bracket to the pad.

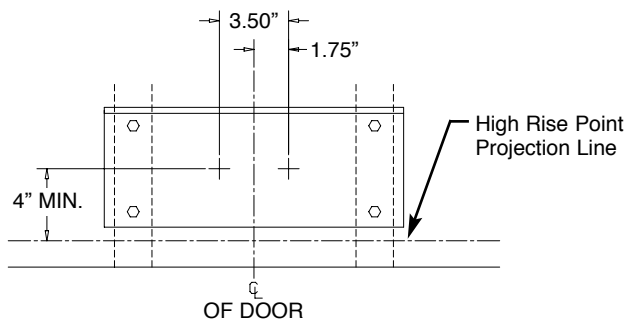

Header Bracket Drill Pattern

## MOUNT OPERATOR

1. Allowing the motor to rest on the floor, raise the front end of the track assembly to the front header bracket and fasten using the 3/8" dia. x 6.40" long pivot shaft and cotterpins supplied.

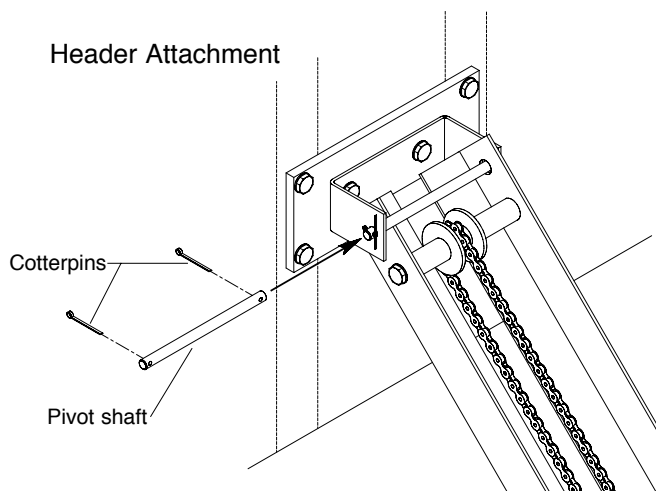

2. Swing the operator to a horizontal position above the guide rails and temporarily secure with a suitable rope, chain, or support from the floor. Now open garage door slowly, being careful not to dislodge the temporary support. Using the door as a support, place a level against the rail and shim the operator until it is horizontal. Make sure that the operator is aligned with the center line of the door.

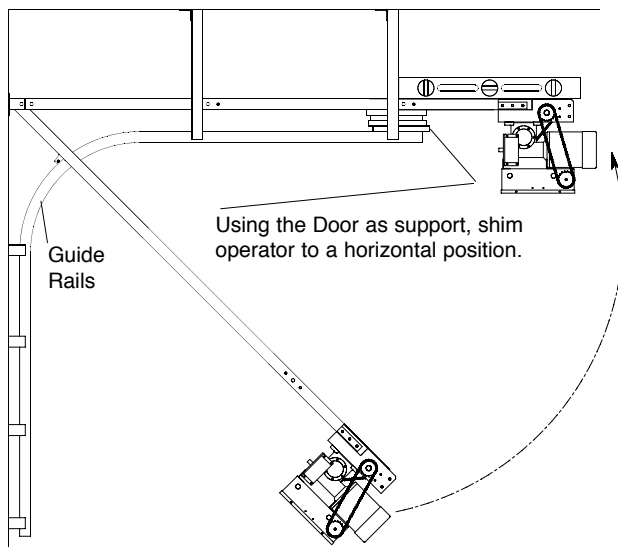

Operator Alignment

# INSTALLATION INSTRUCTIONS

## OPERATOR SUPPORT

1. The illustration below shows a typical method of hanging the operator from the ceiling. Each installation may vary, but in all cases side braces should be used for additional strength.

2. For mounting of the support brace(s) to the powerhead, Four holes (clearance up to 3/8" bolts) are located on each side of frame.

NOTE: If the operator is longer than 15 feet, use of a mid-span support is recommended.

**WARNING**

**FAILURE TO SUSPEND THE OPERATOR SECURELY MAY RESULT IN SERIOUS PERSONAL INJURY OR DEATH, AND/OR PROPERTY DAMAGE.**

## STRAIGHT ARM ATTACHMENT

1. Fully close the door and move the trolley slider to within (2") two inches of the front idler.

2. Latch the straight door arm to the fixed roll pin in the trolley carriage. Make sure the open side of notch on the arm faces the doorway.

3. Attach the door bracket to the door arm using the 3/8"-16 x 1" bolt and nylon locking nut provided. Leave the nut and bolt loose enough to allow the two pieces to pivot freely.

4. Using 3/8" hardware provided, bolt the curved door arm to the straight arm, aligning the mounting holes in such a way that the door bracket pivot bolt will be in line with the top rollers on the door.

5. Position the door bracket to the center line on the door. Using suitable hardware, attach the door bracket to the door. Many installations, except solid wood doors, will require additional support for the door. Refer to the illustration below.

**IMPORTANT NOTE:** At this time, ensure all bolts and lag screws are properly secured.

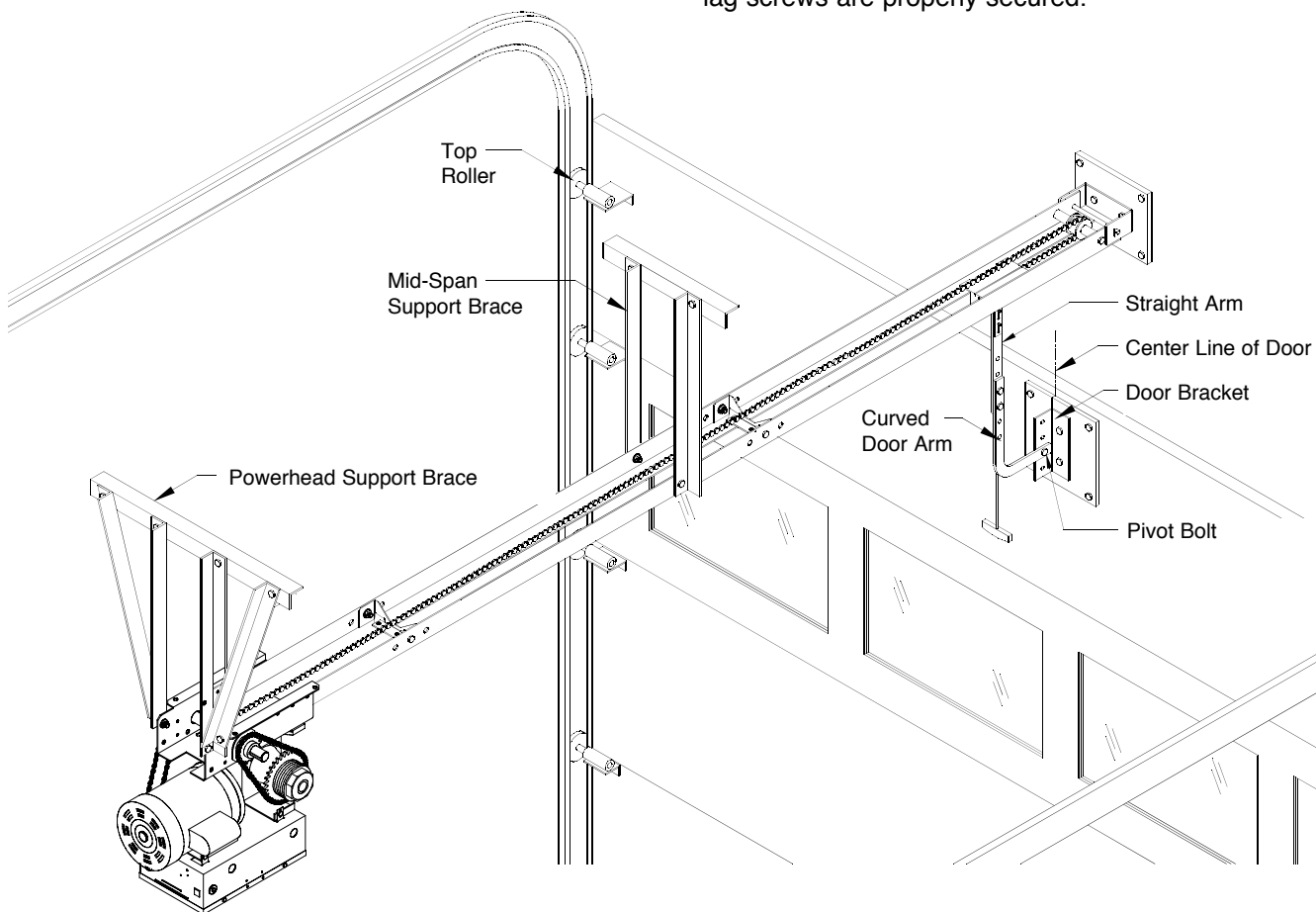

## ENTRAPMENT PROTECTION ACCESSORIES (OPTIONAL)

### PHOTO EYES & SENSING EDGES

Sensing devices supplied for door industry type operators with an isolated normally open (N.O.) dry contact output are compatible with your operator. This includes through beam and retro reflective photo eyes, and pneumatic and electric edges. If your door does not have bottom safety photo eyes or a sensing edge and you wish to add a safety device to your application, please contact your local LiftMaster Authorized Dealer.

If not pre-installed by the door manufacturer, mount the sensing edge on the door according to the instructions provided with the edge. The sensing edge may be electrically connected by either coiled cord or take-up reel.

#### Important Notes:

- a) Proceed with Limit Switch Adjustments before making any sensing edge wiring connections to operator as described below.
- b) Electrician must hardwire the junction box to the operator electrical box in accordance with local codes.

## NOTICE

**IT IS STRONGLY RECOMMENDED THAT A SAFETY PHOTO EYE OR SENSING EDGE BE USED IN CONJUNCTION WITH THE OPERATOR.**

#### WIRING:

For wiring of your sensing device to the operator, refer to the wiring diagram supplied on pages 11 - 13. See field connection terminals identified as Reversing Device.

**TAKE-UP REEL:** Take-up reel should be installed 12" above the top of the door.

**COIL CORD:** Connect operator end of coil cord to junction box (not supplied) fastened to the wall approximately halfway up the door opening.

## LIMIT SWITCH ADJUSTMENT

**MAKE SURE THE LIMIT NUTS ARE POSITIONED BETWEEN THE LIMIT SWITCH ACTUATORS BEFORE PROCEEDING WITH ADJUSTMENTS.**

1. To adjust limit nuts depress retaining plate to allow nut to spin freely. After adjustment, release plate and ensure it seats fully in slots of both nuts.
2. To **increase** door travel, spin nut **away** from actuator. To **decrease** door travel, spin limit nut **toward** actuator.
3. Adjust open limit nut so that door will stop in open position with the bottom of the door even with top of door opening.
4. Repeat Steps 1 and 2 for close cycle. Adjust close limit nut so that actuator is engaged as door fully seats at the floor.



## WARNING

**TO AVOID SERIOUS PERSONAL INJURY OR DEATH FROM ELECTROCUTION, DISCONNECT ELECTRIC POWER BEFORE MANUALLY MOVING LIMIT NUTS.**

If other problems persist, call our toll-free number for assistance - 1-800-528-2806.

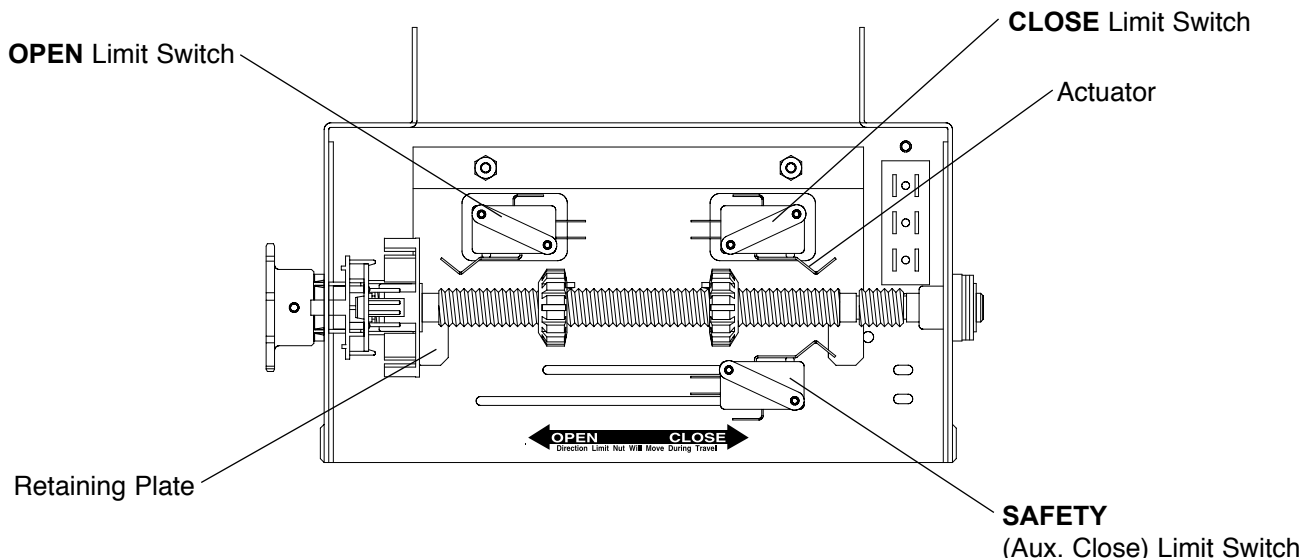

## INSTALL POWER WIRING & CONTROL STATION



Before installing power wiring or control stations be sure to follow all specifications and warnings described below. Failure to do so may result in severe injury to persons and/or damage to operator.



The operator electrical box is only to be accessed by trained "LIFTMASTER" technicians. If service is required contact your local LIFTMASTER dealer.



Do not install any wiring or attempt to run the operator without consulting the wiring diagram. Install the optional Reversing Edge before proceeding with the Control Station installation.



Remove the cover from the electrical enclosure. Inside this enclosure you will find the wiring diagram(s) for your unit. Refer to the diagram (glued on the inside of the cover) for all connections described below. If this diagram is missing, call the number on the back of this manual. **DO NOT INSTALL ANY WIRING OR ATTEMPT TO RUN THIS OPERATOR WITHOUT CONSULTING THE WIRING DIAGRAM.**

### IMPORTANT SAFETY NOTES



#### WARNING

INSTALL THE CONTROL STATION IN LINE OF SIGHT WITH THE DOOR, BUT AWAY FROM THE DOOR AND ITS HARDWARE. IF CONTROL STATION CANNOT BE INSTALLED WHERE DOOR IS VISIBLE, OR IF ANY DEVICE OTHER THAN THE CONTROL STATION IS USED TO ACTIVATE THE DOOR, *A REVERSING DEVICE MUST BE INSTALLED ON THE BOTTOM OF THE DOOR.* FAILURE TO INSTALL A REVERSING DEVICE UNDER THESE CIRCUMSTANCES MAY RESULT IN SERIOUS INJURY OR DEATH.



#### WARNING

ANY MAINTENANCE TO THE OPERATOR OR IN THE AREA NEAR THE OPERATOR MUST NOT BE PERFORMED UNTIL DISCONNECTING THE ELECTRICAL POWER AND LOCKING-OUT THE POWER VIA THE MAIN DISCONNECT SWITCH. UPON COMPLETION OF MAINTENANCE THE AREA MUST BE CLEARED AND SECURED, AT THAT TIME THE UNIT MAY BE RETURNED TO SERVICE.



#### WARNING

TO AVOID DAMAGE TO DOOR AND OPERATOR, MAKE ALL DOOR LOCKS INOPERATIVE. SECURE LOCK(S) IN "OPEN" POSITION. IF THE DOOR LOCK NEEDS TO REMAIN FUNCTIONAL, INSTALL AN INTERLOCK SWITCH.



#### WARNING

DISCONNECT POWER AT THE FUSE BOX BEFORE PROCEEDING. OPERATOR MUST BE PROPERLY GROUNDED AND CONNECTED IN ACCORDANCE WITH LOCAL ELECTRICAL CODES. NOTE: THE OPERATOR SHOULD BE ON A SEPARATE FUSED LINE OF ADEQUATE CAPACITY. ALL ELECTRICAL CONNECTIONS MUST BE MADE BY A QUALIFIED ELECTRICIAN.



# INSTALL POWER WIRING & CONTROL STATION (CONT'D)

## POWER WIRING

### POWER WIRING CONNECTIONS

1. Connect power wires coming from the main to the captive terminal block in the electrical box enclosure marked with the label shown below.

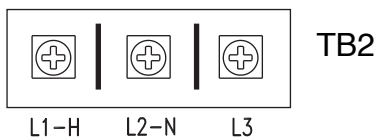

2. Be sure to run all power wires through the conduit hole in the electrical box enclosure marked with the label shown below.

**POWER WIRING**  
USE COPPER WIRE ONLY 40-10031B

**ON THREE PHASE MACHINES ONLY!** Incorrect phasing of the power supply will cause the motor to rotate in the wrong direction.

## GROUND WIRING

1. Connect earth ground to the chassis ground screw in the electrical box enclosure marked with the label shown below.



2. Use same conduit entry into the electrical box as the power wiring.

**IMPORTANT: THIS UNIT MUST BE PROPERLY GROUNDED. FAILURE TO PROPERLY GROUND THIS UNIT COULD RESULT IN ELECTRIC SHOCK AND SERIOUS INJURY.**

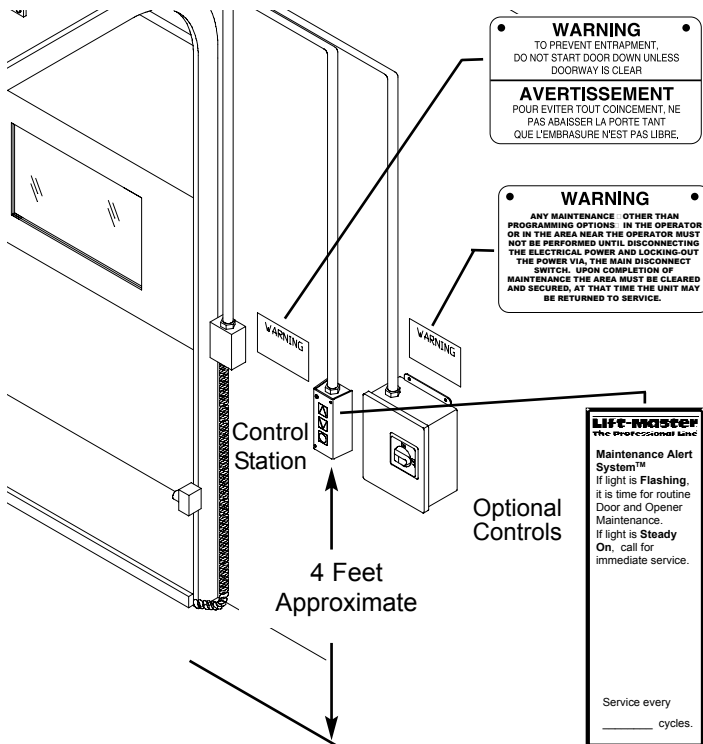

## CONTROL STATION WIRING

### CONTROL WIRING CONNECTIONS

1. Connect control wires to the TB1 terminal block located on the Printed Circuit Board (shown below).

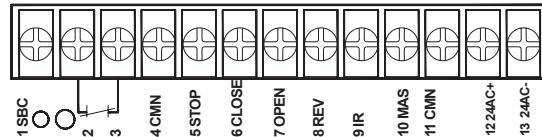

1	SBC	SINGLE BUTTON CONTROL
2	INTERLOCK	INTERLOCK
3	INTERLOCK	INTERLOCK
4	CMN	COMMON
5	STOP	STOP
6	CLOSE	CLOSE
7	OPEN	OPEN
8	REV	REVERSE
9	IR	INFRARED PHOTO EYES
10	MAS	MAINTENANCE ALERT SYSTEM
11	CMN	COMMON
12	24AC+	24 VOLT AC
13	24AC-	24 VOLT AC

2. Be sure to run all control wires through the conduit hole in the electrical box enclosure marked with the label shown below.

**CONTROL WIRING**  
USE COPPER WIRE ONLY 40-10031B

3. Apply power to the operator. Press OPEN push button and observe direction of door travel and then **Press the STOP button.**

If door did not move in the correct direction, check for improper wiring at the control station or between operator and control station.

## RADIO CONTROLS

On all models with B2 control wiring, a terminal bracket marked R1 R2 R3 is located on the outside of the electrical enclosure. Any commercial type LiftMaster brand receiver may be mounted to this bracket. The operator will then open a fully closed door, close a fully open door, stop an opening door, and reverse a closing door from the radio transmitter. In TS control wiring the operator will only open the door or reset the timer to close. However, for additional door control from a 3 button transmitter, a commercial three-channel radio receiver (with connections for OPEN/CLOSE/STOP) is recommended.

## MOUNTING INSTRUCTIONS

1. Mount Control Stations no further than (12") from each other.
2. Mount Control Stations (12") from the door enclosure.
3. Mount WARNING NOTICE beside or below the Control Station.
4. Mount MAINTENANCE ALERT label to either side of control station.

## EMERGENCY DISCONNECT SYSTEM



### WARNING

**DOOR ARM IS RELEASED FROM TROLLEY WHEN EMERGENCY DISCONNECT OPENS.**  
**TO AVOID BEING STRUCK BY DOOR ARM, DO NOT STAND UNDER THE ROPE OR DOOR ARM WHEN PULLING THE EMERGENCY RELEASE.**

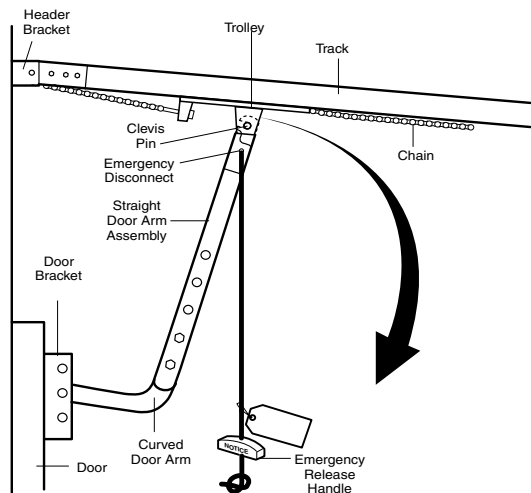

#### TO DISCONNECT DOOR FROM OPENER

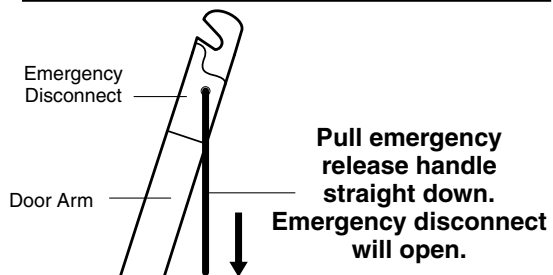

#### TO RECONNECT DOOR ARM TO TROLLEY

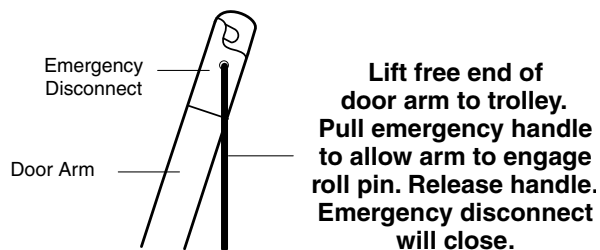

## TORQUE ADJUSTMENT

1. Loosen set screws of torque adjustment nut on the gear reducer.
2. Back off torque nut until there is very little tension on the belleville washers.
3. Tighten torque nut gradually until there is just enough tension to permit the operator to move the door smoothly through a complete open/close cycle, but to allow the reducer to slip if the door is obstructed.
4. Re-tighten the set screw that is directly over the flat portion of the shaft.

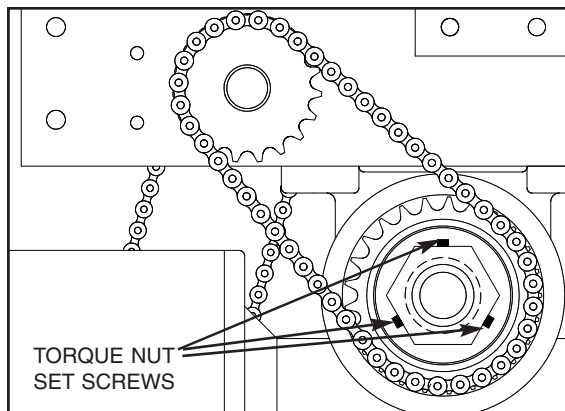

## BRAKE ADJUSTMENT

A solenoid brake is standard on GT operators. The brake is adjusted at the factory and should not need additional adjustment for the the life of the friction pad.

Replace friction pads when necessary. Refer to the illustration for identification of components for the solenoid type brake system.

#### Solenoid Brake System

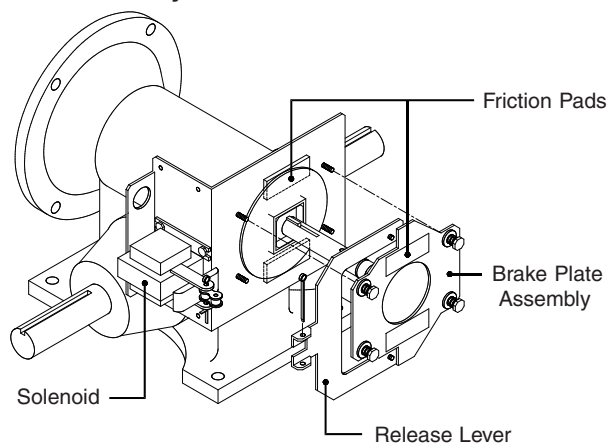

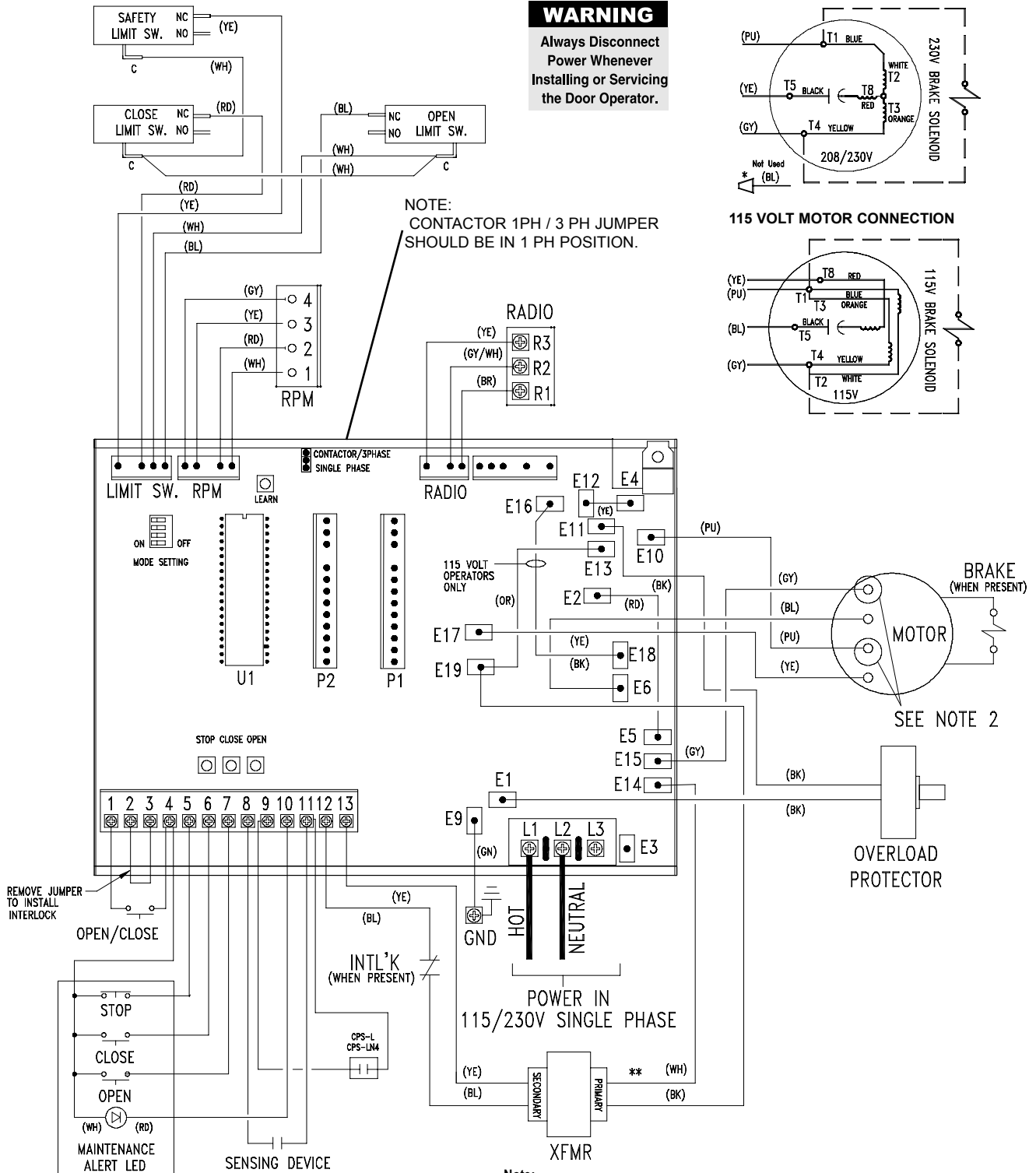

**WARNING**  
Always Disconnect Power Whenever Installing or Servicing the Door Operator.

**230 VOLT MOTOR CONNECTION**

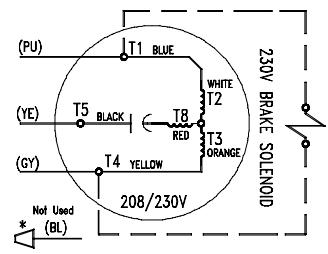

**115 VOLT MOTOR CONNECTION**

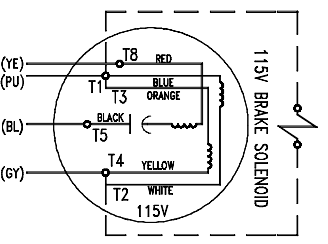

- Note:**
- 1) See Owner's Manual for Dip Switch Functions and Programming Procedures
  - 2) TO REVERSE MOTOR DIRECTION  
 115 VOLTS: ALWAYS EXCHANGE PURPLE & GRAY ALL VOLTS & PHASES.  
 230 VOLTS: INTERCHANGE PURPLE (E10) & GRAY (E15) WIRES AT LOGIC BOARD.  
 \* - BLUE WIRE MUST BE INSULATED ON 230V 1PH.  
 \*\* - Transformer Primary Voltage same as Line Voltage..

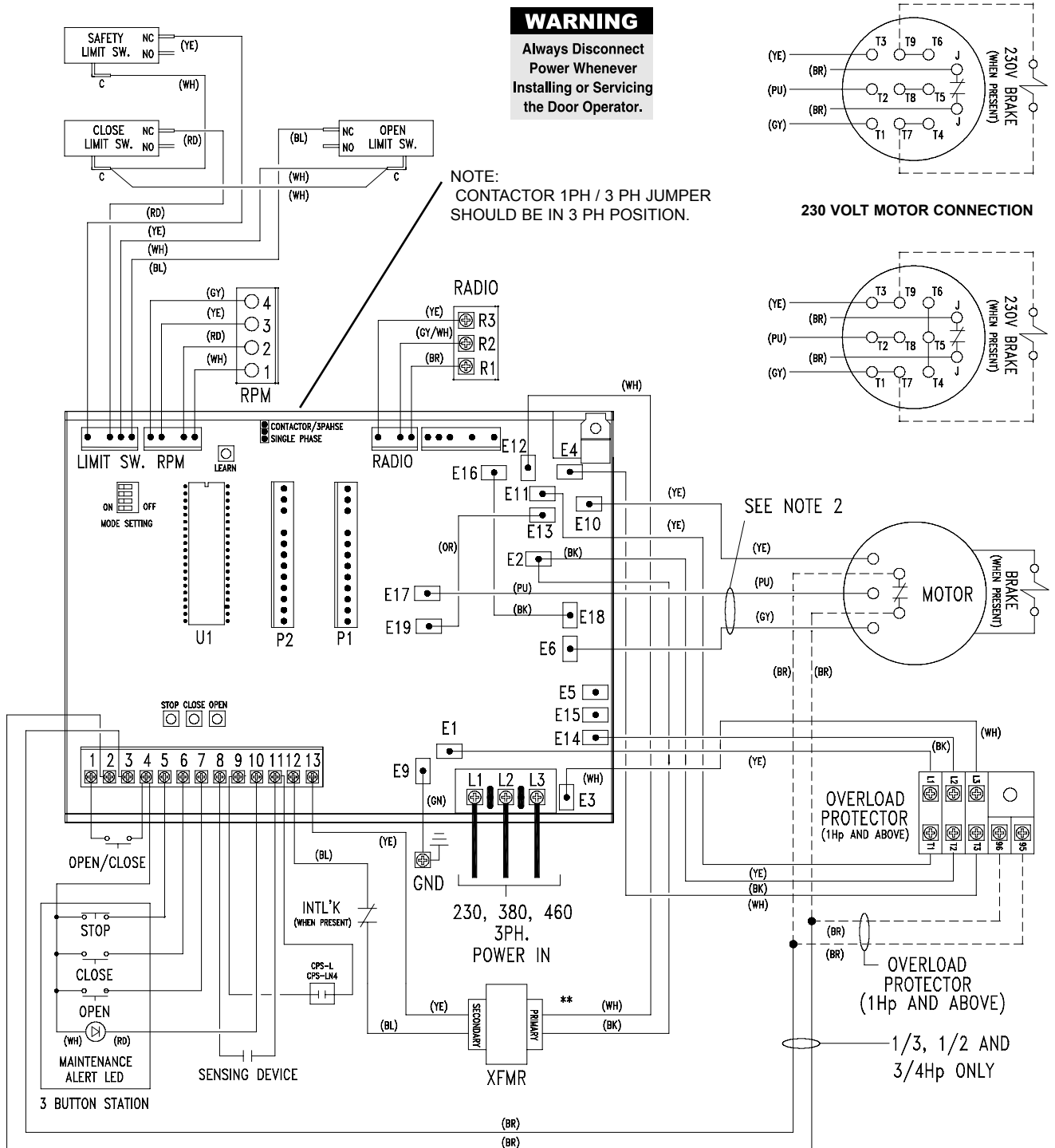

**WARNING**  
Always Disconnect Power Whenever Installing or Servicing the Door Operator.

NOTE:  
CONTACTOR 1PH / 3 PH JUMPER SHOULD BE IN 3 PH POSITION.

380/460 VOLT MOTOR CONNECTION

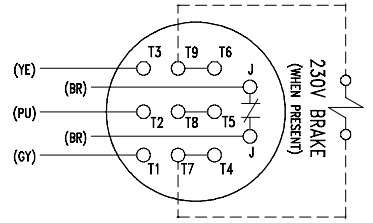

230 VOLT MOTOR CONNECTION

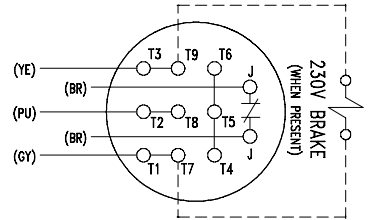

SEE NOTE 2

- Notes:
- 1) See Owner's Manual for Dip Switch Functions and Programming Procedures
  - 2) TO REVERSE MOTOR DIRECTION: INTERCHANGE ANY 2 OF THE 3 POWER WIRES  
AT L1, L2 & L3, OR EXCHANGE PURPLE & GRAY MOTOR LEADS AT BOARD CONNECTIONS E17 & E6 (3PH UNITS ONLY).
- \*\* - Transformer Primary Voltage same as Line Voltage.

# LOGIC CONTROL (VER. 2.0) 1 PH WIRING DIAGRAM W/ CONTACTOR 1842-1

**WARNING**  
Always Disconnect Power Whenever Installing or Servicing the Door Operator.

NOTE:  
CONTACTOR 1PH / 3 PH JUMPER SHOULD BE IN 1 PH POSITION.

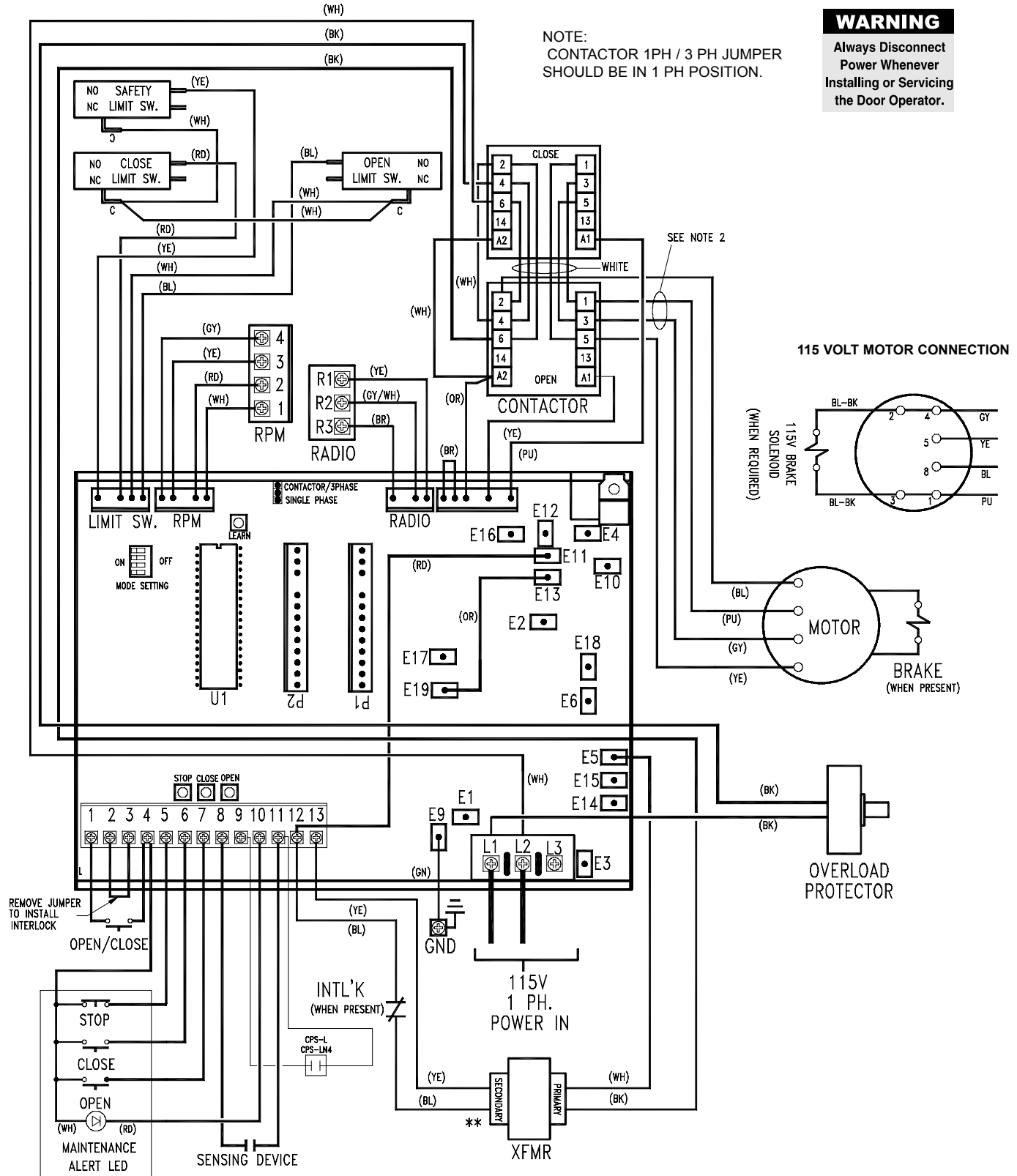

**115 VOLT MOTOR CONNECTION**

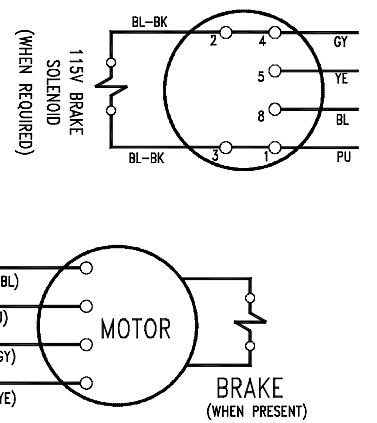

3 BUTTON STATION

Note:  
1) See Owner's Manual for Dip Switch Functions and Programming Procedures  
2) TO REVERSE MOTOR DIRECTION  
115 & 230 VOLTS: INTERCHANGE PURPLE & GRAY WIRES AT CONTACTOR.  
\*\*. Transformer Primary Voltage same as Line Voltage.



Refer to printed circuit board illustration on page 19 for all component locations.



Before Programming the logic board, set the operators open and close limits. LEDs on the logic board are provided to assist setting the limits. As each limit is activated the corresponding LED will light up. The abbreviations are Open Limit Switch (OLS), Close Limit Switch (CLS) and Sensing Limit Switch (SLS). Refer to page 7 for limit switch adjustment instructions.

**Logic Control Pushbuttons Open, Close, Stop**

Open, Close and Stop buttons are mounted directly on the Logic Control board. This will provide easy programming ability and door control at the electrical box. Either the stop control or a jumper must be wired between terminals 4 and 5 for the on board push buttons to function.

**WIRING TYPE PROGRAM SETTINGS**

**Determine wiring mode:**

There are many wiring modes available on the Logic Board. Read the descriptions of the different wiring types to determine which setting will be correct for each application.

**Set the dip switches to the desired wiring mode:**

Adjust the 4 dip switches on the logic board to match the settings for the desired wiring type. The dip switches are shown in the picture

**TYPE STATION**

**C2** 3 Button, 3 Button Radio Control

Function: Momentary contact to open and stop with constant pressure to close, open override plus wiring for sensing device to reverse. Programmable mid stop available with this wiring type.

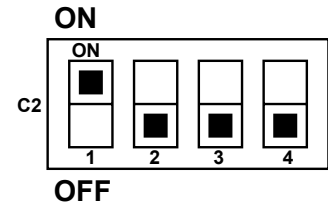

**B2** 3 Button, 1 Button, 1 & 3 Button Radio Control

Function: Momentary contact to open, close and stop, plus wiring for sensing device to reverse and auxiliary devices to open and close with open override. Programmable mid stop available with this wiring type.

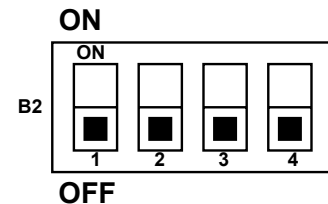

**D1** 2 Button, 3 Button Radio Control

Function: Constant pressure to open and close with wiring for sensing device to stop.

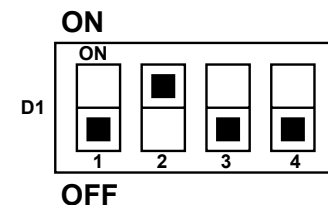

**E2** 3 Button Radio Control

Function: Momentary contact to open with override and constant pressure to close. Release of close button will cause door to reverse (roll-back feature) plus wiring for sensing device to reverse.

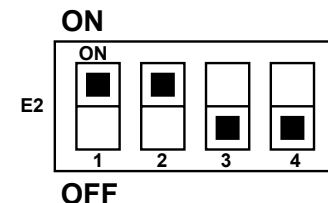

**TS** 3 Button, 1 Button, 1 & 3 Button Radio Control

Function: Momentary contact to open, close, and stop with open override and Timer To Close. Every device that causes door to open, including a reversing device, activates the Timer To Close. Auxiliary controls can be connected to open input to activate the Timer To Close. If the timer has been activated, the open button and radio control can recycle the timer. The stop button will deactivate the Timer To Close until the next command input. The Timer To Close will function from the programmable mid-stop with this wiring type. **(NOTE: Requires Optional self monitoring photo eyes to operate.)**

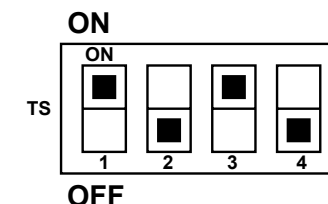

## WIRING TYPE PROGRAM SETTINGS CONT'D

**TYPE      STATION**

**T**            3 Button, 1 Button, 1 & 3 Button Radio Control

Function: Momentary contact to open, close, and stop, with open override and Timer To Close. Every device that causes the door to open, except a reversing device, activates the Timer To Close. Auxiliary controls can be connected to open input to activate the Timer To Close. If the Timer To Close has been activated, the open button and radio control can recycle the timer. The stop button will deactivate the timer until the next command input. The Timer to Close will function from the programmable mid-stop with this wiring type. **(NOTE: Requires Optional self monitoring photo eyes to operate.)**

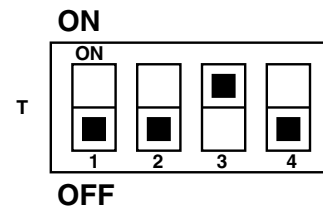

**FSTS**            Momentary button contact for open, close and stop. Radio controls allowing open, close and stop. User set midstop. User set Timer To Close. The single button station opens the door to the full open limit bypassing the mid stop and activates the Timer To Close, putting the operator in TS mode until the door reaches the down limit, or is stopped in travel. At which time the operator enters the B2 mode. **(NOTE: Requires Optional self monitoring photo eyes to operate.)**

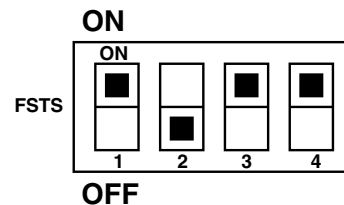

**C2 Failsafe**            3 Button, 3 Button Radio Control  
Same functions as C2. Self Monitoring safety device must be installed to operate door. See Self Monitoring Safety Device Options below.

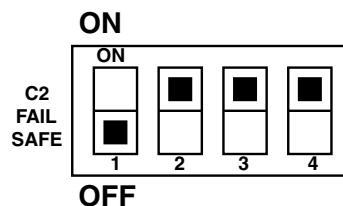

**B2 Failsafe**            3 Button, 1 Button, 1 & 3 Button Radio Control  
Same functions as B2. Self Monitoring safety device must be installed to operate door. See Self Monitoring Safety Device Options below.

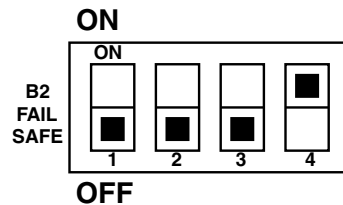

**D1 Failsafe**            2 Button, 3 Button Radio Control  
Same functions as D1. Self Monitoring safety device must be installed to operate door. See Self Monitoring Safety Device Options below.

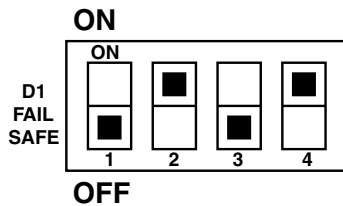

**E2 Failsafe**            2 Button, 3 Button Radio Control  
Same functions as E2. Self Monitoring safety device must be installed to operate door. See Self Monitoring Safety Device Options below.

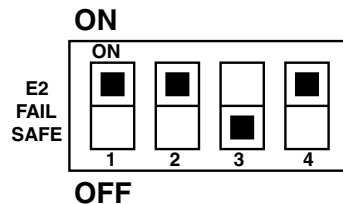

## SELF MONITORING SAFETY DEVICE OPTIONS

To use the operator in any of the Failsafe wiring modes, or Timer To Close wiring modes (TS, T, FSTS), a LiftMaster self monitoring safety device must be installed.

**Recommended LiftMaster Self Monitoring Safety Devices:**

- CPS-L**      NEMA 1 Direct Connect Eyes
- CPS-LN4**    NEMA 4 Direct Connect Eyes

**NOTE:**

1. External interlocks may be used with all functional modes.
2. Auxiliary devices are any devices that have only dry contacts. Examples are: photocell, loop detector, pneumatic or electrical treadles, radio controls, one button stations, pull cords, etc.
3. Open override means that the door may be reversed while closing by activating an opening device without the need to use the stop button first.

## STANDARD PROGRAMMING FEATURES

### RPM Sensor/Auxiliary Reversal System (Programming is Recommended)

**Feature:** By programming the RPM sensor to a specific application, the logic board learns the speed the door travels with reference to the spinning motor. This sensor activates the start winding and recognizes clutch slippage.

**Benefit:** By removing the centrifugal start switch from 1/3 and 1/2 horsepower single-phase motors the leading cause of motor failure is eliminated. The auxiliary reversing benefits of the RPM sensor are designed to prevent excessive door and operator damage upon hitting a solid obstruction. LiftMaster recommends the use of safety devices for primary safety protection.

#### **To Program:**

1. The open and close limits must be set before setting the RPM sensor.
2. Start with the door closed and turn all dip-switches to the off position.
3. Press open then press and hold the "learn" button on the Logic board until the door reaches the full open position. You should see the Learn LED turn off after pressing the learn button; it will turn back on about 5 seconds later. If the LED did not cycle, start over and wait about 1/4 to 1/2 second between pressing "open" and "learn".
4. Return the dip switches to your regular wiring type (C2, B2, etc.) and close the door.

**Note:** LiftMaster 2.0 Logic operators are designed to work in most cases without adjusting the RPM sensor. It is still recommended to set this feature on every installation. This feature will need to be reset if the motor or logic board is ever replaced.

### Maximum Run Timer (Setting is Recommended)

**Feature:** The door will run in one direction for a set amount of time. Default time is 90 seconds. Installer can adjust the 90 second timer to the open cycle plus 10 seconds.

**Benefit:** Should the door hit an obstruction that is not detected by a sensor, it will stop after the programmed amount of time and not continue to drive into the obstruction. This may help prevent prolonged human entrapment as well as help prevent damage to the door and operator.

#### **To Program:**

1. Start with the door closed and the limits set.
2. Set the dip switches to "set Max Run Timer".
3. Press Open and wait for the door to reach the full open limit.
4. Return the dip switches to the desired wiring type (C2, B2, etc.) and Close the door. The Maximum Run Timer is now set and will allow the door to move in one direction no more than 10 seconds longer than it normally takes to travel from close to open.

**Example:** If it takes the door 13 seconds to open normally, the operator will stop running after 23 seconds. If the Max Run Timer is not programmed, it will run for 90 seconds total in either direction.

**Note:** For very large, slow moving doors, where the normal travel time is close to 90 seconds setting the MRT is essential to move the door the full travel distance.

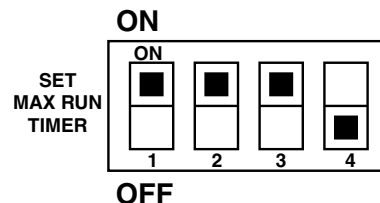
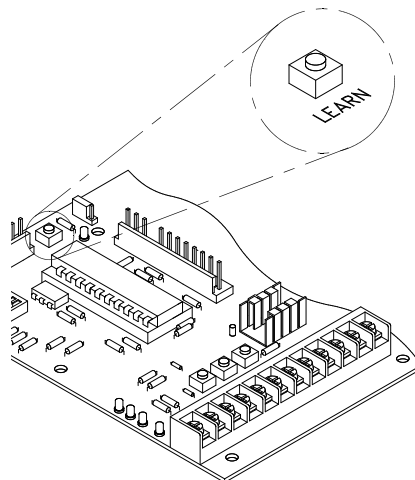



## STANDARD PROGRAMMING FEATURES CONT'D

### MAS (Maintenance Alert System)

**Feature:** An internal cycle counter will activate a flashing LED on the three-button control station when the preset number of cycles is reached. Setting this feature is optional. By default, this feature will never activate.

**Benefit:** The consumer will be aware of when it is time for a scheduled maintenance on the door or operator.

**To Program:**

1. Close the door.
2. Set the dip switches to "set Maintenance Alert System"
3. Press "close" to zero out the counter.
4. Press "open" for every 5,000 cycles the operator should wait before flashing the LED.
5. Return the dip switches to your regular wiring type (C2, B2, etc.) and close the door.

**EXAMPLE:** The door is being installed with 30 thousand cycle springs. To set the MAS for 30,000 cycles press close, then open 6 times. Return the dip switches to the desired wiring type.

**Special Notes about the MAS:** A 5th wire must be run to the control station to activate the MAS LED. When the operator is serviced after the MAS has started the LED flashing, repeat the setup procedure for the next service visit. To see how many cycles the operator has been through set the dip switches to "set MAS" and watch the MAS led. It will flash once for every 1000 cycles the operator has been used then pause and repeat. Every time the operator leaves the close limit is counted as one cycle.

Press This	To Get This
Open	Adds 5,000 cycles to Maintenance Alert System Activation Counter.
Close	Clears memory, sets Maintenance Alert System Activation Counter to 0 cycles.
Stop	Adds 10,000 cycles to Maintenance Alert System Activation Timer.

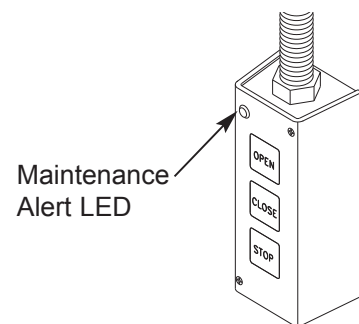
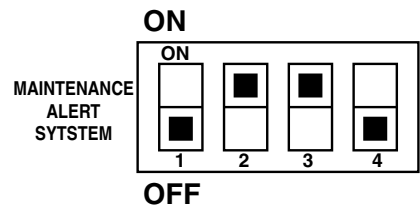

## OPTIONAL PROGRAMMING FEATURES

### Mid Stop

**Feature:** Door will open to an installer set height that is less than fully open.

**Benefit:** The door will not open fully which will reduce unwanted airflow through the doorway. The door will not cycle fully providing longer door and operator life.

**To Program:**

1. Close the door.
2. Set dip switches to "set mid stop".
3. Press open (the door will begin moving)
4. Press stop when the desired mid stop height is reached.
5. Return the dip switches to the desired wiring type (C2,B2,etc.). The door will now stop at this height every time the door is opened.

**Notes:** A momentary open command will open the door fully from the mid stop position. Photo eyes and other safety devices will not further open the door from the mid stop position. Timer To Close will work from the mid stop position.

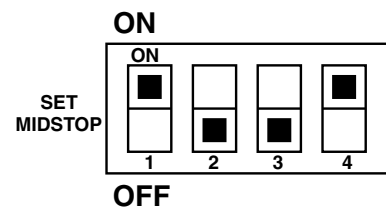

## OPTIONAL PROGRAMMING FEATURES CONT'D

### Timer To Close

**Feature:** Installer can set a timer to automatically close after a preset amount of time once all safety devices are unobstructed.

**Benefits:** Door will automatically close after being used. Extremely convenient where users may not be concerned with closing the door. For example Apartment Buildings and Fire Stations.

**Requirements:** Must have at least one of the following safety devices attached: CPS-L, CPS-LN4, CPSII, CPSII-N4. When running, the dip switches must be set for TS, T, or FSTS

**To Program:**

1. Close the door.
2. Set dip switches to "Set Timer To Close"
3. Press "close" to zero out the timer.
4. Press "open" for every 5 seconds the operator should wait before attempting to close the door.

**Example:** The door is supposed to close 30 seconds after the user drives through. To set the TTC for 30 seconds press close, then open 6 times.

5. Return the dip switches to the desired wiring type. TS, T, or FSTS

**Notes:** For longer delay time settings, use the Single Button Control (terminal 1) to add 1 minute at a time. To deactivate the timer press stop. The timer will be reactivated on the next operation command.

**Reminders:** FSTS wiring mode allows the Timer To Close to be activated by the Single Button Control (terminal 1) only. T wiring mode allows the door to attempt to close only one time for safety purposes.

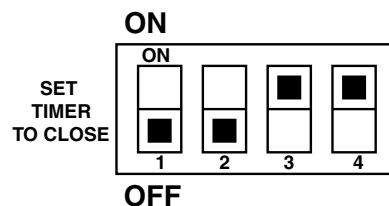

Press This	To Get This
Open	Adds 5 seconds to countdown timer.
Close	Resets the timer to close to 0 seconds. Turns off electronic search for photo eyes after photo eyes have been intentionally removed.
Stop	Adds 5 seconds to "Red warning light before closing" time.
Single Button Control	Adds 60 seconds to countdown timer.

### Adjusting your red/green warning lights

**Feature:** The logic board can adjust the amount of time that a warning light will flash before the Timer To Close will activate the door to close.

**Benefit:** Advanced warning of door closure helps prevent traffic collisions with the door.

**To Program:**

1. Set the dip switches to "Set Timer To Close"
2. Press stop for every additional 5 seconds of pre-movement warning.
3. Return the dip switches to the desired wiring type.

**Requirements:** Must have the Logic 2 red green warning light kit #001A4730 and must have at least one of the following safety devices attached: CPS-L, CPS-LN4, CPSII, CPSII-N4. When running, the dip switches must be set for TS, T, or FSTS. See red/green warning light instructions for further details.

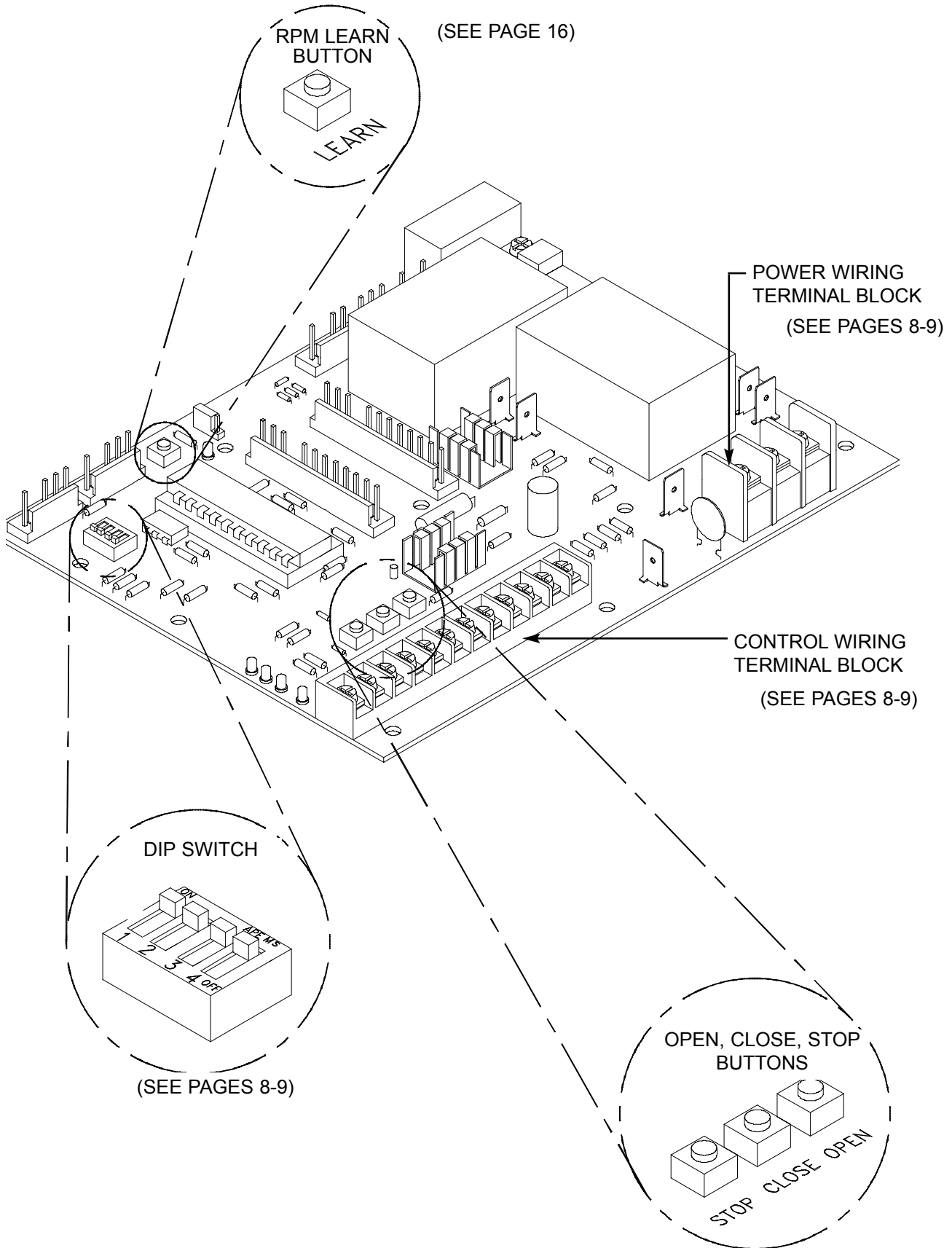

# TROUBLE SHOOTING

## TROUBLESHOOTING GUIDE

SYMPTOM	PROBABLE CAUSE	RESOLUTION
Each open command will open the door about a foot and a half then stop, after reaching the open limit each close command will close the door about a foot and a half then reverses back to full open.	RPM sensor is not adjusted correctly.	Reset the RPM sensor. Also verify that the software is version 260 or better. Order replacement chips from Parts and Service.
The door will open some but not completely. And the door will close some and not completely. Extra commands are able to get the door to move completely	The Maximum run timer is not set correctly.	Reset the Maximum Run Timer
The door will open some but not completely. An extra open command is able to get the door to open completely	There may be a Mid Stop set.	Reset the mid-stop by programming it to be at the open limit.
The door will open but will only close after a 5 second delay with constant pressure on the close button.	<ul style="list-style-type: none"> <li>a) The Photo Eyes, edge or other sensing device is obstructed or activated.</li> <li>b) The Logic board thinks that the direct connect photo eyes are attached and blocked</li> </ul>	<ul style="list-style-type: none"> <li>a) Remove the obstruction, check the safety device wires for continuity and shorts.</li> <li>b) Unlearn the photo eyes from the memory (see clear memory section). Also verify that the Logic Board Chip is Version 260 or better. Order replacement Chips from Parts and Service.</li> </ul>
The operator will not respond to any commands	<ul style="list-style-type: none"> <li>a) Operator control station is wired wrong</li> <li>b) Motor is malfunctioning</li> </ul>	<ul style="list-style-type: none"> <li>a) Use the LEDs to help check correct wiring (see Diagnostic procedure) Verify that the board is accepting commands by using the onboard control station.</li> <li>b) Verify voltage getting to the motor.</li> </ul>

### Clearing The Memory 3 - steps

#### **STEP 1: To reset most of the user installed settings back to factory defaults:**

1. Turn all the dip switches **ON**.
2. Press and hold the Learn button about 5 seconds.
3. The Learn LED will turn off while you hold the button down and turn back on about 5 seconds later.
4. Return the dip switches to the desired wiring type.

- Note:**
- A. The Max Run Timer is now set to 90 seconds
  - B. The Timer To Close is now set to 0 seconds
  - C. The Mid Stop is now deactivated
  - D. The Maintenance Alert System is now deactivated

**Note:** To clear the Mid Stop only Set/Program the Mid Stop at the open limit. The logic board understands this to mean that no mid stop is desired.

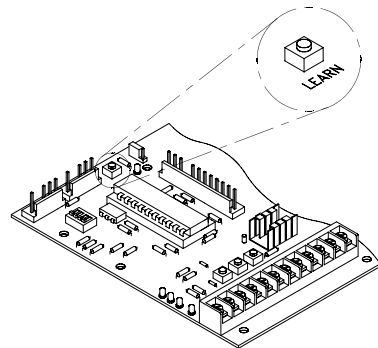

# TROUBLE SHOOTING

**STEP 2: To "unlearn" the photo eyes.** The latest software automatically learns if direct connect photo eyes (CPS-L or CPS-LN4) are attached during the first open cycle of operation. If they are disconnected at some point after this, they must be unlearned.

1. Set the dip switches to set Timer To Close.
2. Press Open 2 times then Close 2 times and then Stop 2 times (order is not specific).
3. Return the dip switches to the desired wiring type.

**STEP 3: Relearn RPM.** Because factory default is set without a door attached to the operator, factory default setting is not a preferred status.

1. Start with the door closed and set all Dip switches to the off position.
2. Press open then press and hold the "learn" button on the Logic board (see picture) until the door reaches the full open position. You should see the Learn LED turn off after pressing the learn button; it will turn back on about 5 seconds later. If the LED did not cycle, start over and wait about ¼ to ½ second between pressing "open" and "learn".
3. Return the dip switches to your regular wiring mode and close the door.

### **Diagnostic LEDs**

There should always be 3 green LEDs activated (24 VAC, 5 VDC, and STOP Button). Check for this first then proceed to check the status of the remaining LEDs

ORDER	LED	COLOR	MEANING OF EACH LED
1	24VAC	Green	Indicates that 24 VAC is being received from the transformer
2	5VDC	Green	Indicates that 5VDC is being generated for the logic board to use
11	Diag	Red	Indicates that the MAS LED on the 3 button control station is being turned on.
10	REV	Red	Indicates a short between common and terminal 8. Pressing the edge should turn ON this LED
4	Open	Red	Indicates a short between common and terminal 7. Pressing the open button should turn ON this LED
5	Close	Red	Indicates a short between common and terminal 6. Pressing the close button should turn ON this LED
3	Stop	Green	Indicates a short between Common and terminal 5. Pressing the stop button should turn OFF this LED.
6	SBC	Red	Indicates a short between Common and terminal 1. Pressing the Single Button Control station should turn ON this LED.
7	OLS	Red	Indicates the Open Limit Switch being pressed
8	CLS	Red	Indicates the Close Limit Switch being pressed
9	SLS	Red	Indicates the Sensing Limit Switch being pressed
12	Learn	Amber	This LED is normally on and in Diagnostic mode (all dip switches on) this LED will flash to indicate the chip is OK.

### **Diagnostic Checklist Procedure**

1. Look for the 3 Green LEDs
  - A. If the 24 VAC light is out, check the transformer and any interlock switches, then replace either the transformer or the logic board.
  - B. If the 5 VDC light is out, and the 24VAC is lit, replace the board.
  - C. If the Stop Button light is out, check the wiring to the control station, if the site does not require a stop button use a jumper across terminals 4 and 5. If the LED is still not lit call for more assistance.
2. Check your control station:
  - A. Place the operator into diagnostic mode (all DIP switches ON)
  - B. Watch the LEDs as each control button is pressed. The LEDs should light with each Open, Close, and Single Button Control command. The Stop should turn off the LED.
3. Activate the limit switches to verify functionality. Also watch the LED's during door travel to check for over active limit switches.
4. Disconnect all devices and reattach them one at a time testing for failure after each item is replaced. This will determine which device is causing the failure. For further assistance call for technical support.

## MAINTENANCE SCHEDULE

- For use with Maintenance Alert System.
- Check at the intervals listed in the following chart.

ITEM	PROCEDURE	EVERY 3 MONTHS OR 5,000 CYCLES	EVERY 6 MONTHS OR 10,000 CYCLES	EVERY 12 MONTHS OR 20,000 CYCLES
Drive Chain	Check for excessive slack. Check & adjust as required. Lubricate	●		◆
Sprockets	Check set screw tightness	●		◆
Clutch	Check & adjust as required		●	◆
Belt	Check condition & tension		●	◆
Fasteners	Check & tighten as required		●	◆
Manual Disconnect	Check & Operate		●	◆
Bearings & Shafts	Check for wear & Lubricate	●		◆

- ◆ Use SAE 30 Oil (Never use grease or silicone spray).
- ◆ Repeat ALL procedures.
- Do not lubricate motor. Motor bearings are rated for continuous operation.
- Do not lubricate clutch or V-belt.
- Inspect and service whenever a malfunction is observed or suspected.
- CAUTION: BEFORE SERVICING, ALWAYS DISCONNECT OPERATOR FROM POWER SUPPLY.

### HOW TO ORDER REPAIR PARTS

OUR LARGE SERVICE ORGANIZATION  
SPANS AMERICA  
INSTALLATION AND SERVICE INFORMATION  
ARE AVAILABLE 6 DAYS A WEEK  
CALL OUR TOLL FREE NUMBER - 1-800-528-2806  
MONDAY THROUGH FRIDAY 5 AM TO 6 PM (MST)  
SATURDAY 7 AM TO 3:30 PM (MST)  
WWW.LIFTMASTER.COM

**WHEN ORDERING REPAIR PARTS  
PLEASE SUPPLY THE FOLLOWING INFORMATION:  
PART NUMBER DESCRIPTION MODEL NUMBER**

# ILLUSTRATED PARTS – ELECTRICAL BOX

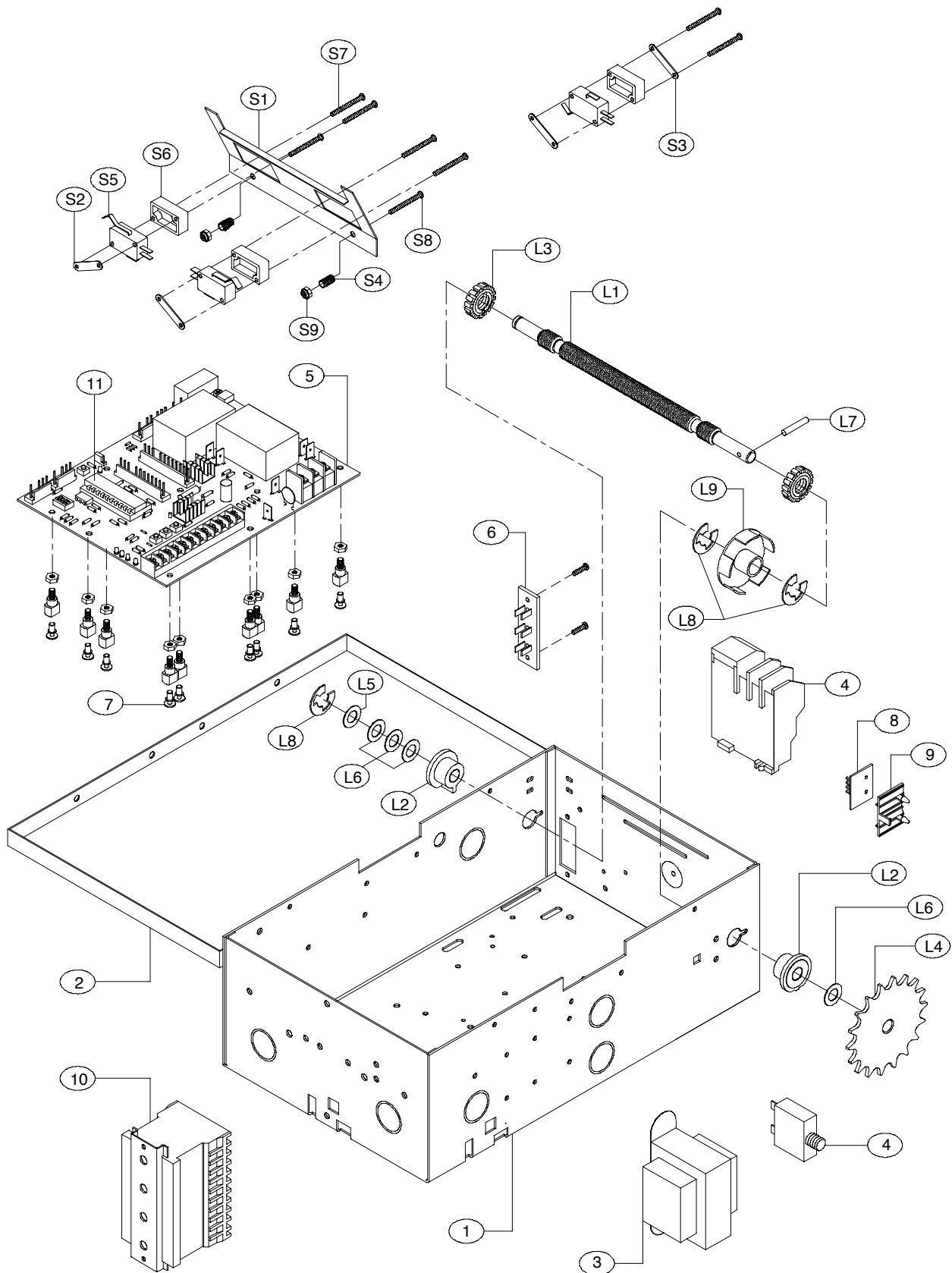

# REPAIR PARTS KITS – ELECTRICAL BOX

LOGIC CONTROL (VER. 2.0)

Below are replacement kits available for your operator. For replacement of electrical box, motor or brake components be sure to match model number of your unit to kit number below to ensure proper voltage requirements. Optional modifications and/or accessories included with your operator may add or remove certain components from these lists. Please consult a parts and service representative regarding availability of individual components of kits specified below. Refer to page 19 for all repair part ordering information.

## Electrical Box Replacement Kits

To order a complete electrical box kit, add a K- prefix to the model number of your operator. For example:

GT5011L (Operator) = K-GT5011L (Electrical box replacement kit)

\* Electrical Box Kits include parts from K72-12418 and K75-12514

## Electrical Box Sub-Assemblies

K72-12418 Limit Shaft Assembly  
K75-12514 Limit Switch Assembly

## Motor Kits

K20-1050C2 Models GT5011M, GT5021M  
K20-3050C4 Models GT5023M, GT5043M, GT5038M  
K20-5150C6 Models GT5025M  
K20-1075C2 Models GT7511M, GT7521M  
K20-3075C4 Models GT7523M, GT7543M, GT7538M  
K20-5175C6 Model GT7525M  
K20-1100C2 Models GT1011M, GT1021M  
K20-3100C4 Models GT1023M, GT1043M, GT1038M  
K20-5110C6 Model GT1025M  
K20-1150C2 Models GT1511M, GT1521M  
K20-3150C4 Models GT1523M, GT1543M, GT1538M  
K20-5115C6 Model GT1525M

## Shaft Assemblies

K75-12858 Torque Limiter Assembly  
K72-12859 Drive Shaft Assembly

## Brake Assemblies

71-B120 Brake Assembly, 115 Volt  
71-B240 Brake Assembly, 230/460 Volt

* COMPLETE ELECTRICAL BOX KITS			
Item	P/N	Description	Qty
1	10-13900	Electrical Box	1
2	10-10115	Electrical Box Cover	1
3	21-XXXX	(See Variable Components)	1
4	25-XXXX	(See Variable Components)	1
5	79-13433	(See Variable Components)	1
6	42-10040	Terminal Block, Radio	1
7	75-13705	Standoff, Assembly	9
8	79-15016	RPM Sensor Board	1
9	093D0148	Housing, RPM Board	1
10	03-8024K	Contactor (See Variable Components)	1
11	29-CDO-XXX	Programmed Chip	1

K72-12510 LIMIT SHAFT ASSEMBLY KIT			
Item	P/N	Description	Qty
L1	11-10021	Limit Shaft, Standard T	1
L2	12-10028	Flange Bearing, 3/8" I.D.	2
L3	13-10024	Limit Nut	2
L4	15-48B18AXX	Sprocket 48B9 x 3/8" Bore	1
L5	80-10025	Washer, Shim 3/8" I.D. x .050 THK.	1
L6	80-10026	Washer, Shim 3/8" I.D. x .010 THK.	4
L7	86-RP04-100	Roll Pin, 1/8 DIA. x 1" Long	1
L8	87-E-038	E Ring, 3/8"	3
L9	29-10344	Rotating Cup	1

K75-12514 LIMIT SWITCH ASSEMBLY KIT			
Item	P/N	Description	Qty
S1	10-10013	Depress Plate	1
S2	10-12553	Nut Plate, Switch	3
S3	10-12806	Backup Plate	1
S4	18-10036	Spring, Depress Plate	2
S5	23-10041	Limit Switch	3
S6	31-12542	Standoff, Limit Switch	3
S7	82-PX04-20	Screw, #4-40 x Pan Head Phillips	6
S8	82-PX06-16	Screw, #6-32 x 1" Pan Head Phillips	2
S9	84-LH-06	Locknut, #6-32 Nylon Hex	2

## VARIABLE COMPONENT KITS

ITEM	PART NO.	DESCRIPTION	GT5011L	GT5021L	GT5023L	GT5043L	GT5053L	GT5025L	GT5038L	GT7511L	GT7521L	GT7523L	GT7543L	GT7553L	GT7525L	GT7538L	GT1011L	GT1021L	GT1023L	GT1043L	GT1053L	GT1025L	GT1038L	GT1511L	GT1521L	GT1523L	GT1543L	GT1553L	GT1525L	GT1538L
3	21-14182	Transformer, 115 Volts	●	●	●			●	●	●	●	●			●	●	●	●	●			●	●	●	●	●	●	●	●	●
	21-5460	Transformer, 460 Volts				●			●				●		●					●			●				●			●
	21-5575	Transformer, 575 Volts					●							●							●							●		
4	25-2006	Overload, 6 Amp		●				●																						
	25-2008	Overload, 8 Amp									●				●			●					●							
	25-2010	Overload 10 Amp	●																						●					●
	25-2015	Overload 15 Amp									●						●													
	25-2020	Overload 20 Amp																						●						
	25-10296	Overload 2.8-4.4 Amp																		●							●			●
	25-11107	Overload 5.2-8.0 Amp																								●				
	25-13840	Overload 2.0-3.0 Amp																			●			●				●		
25-13842	Overload 1.4-2.0 Amp																					●								
10	03-8024K	K-Line Contactor																					●							



# ILLUSTRATED PARTS - MODEL GT

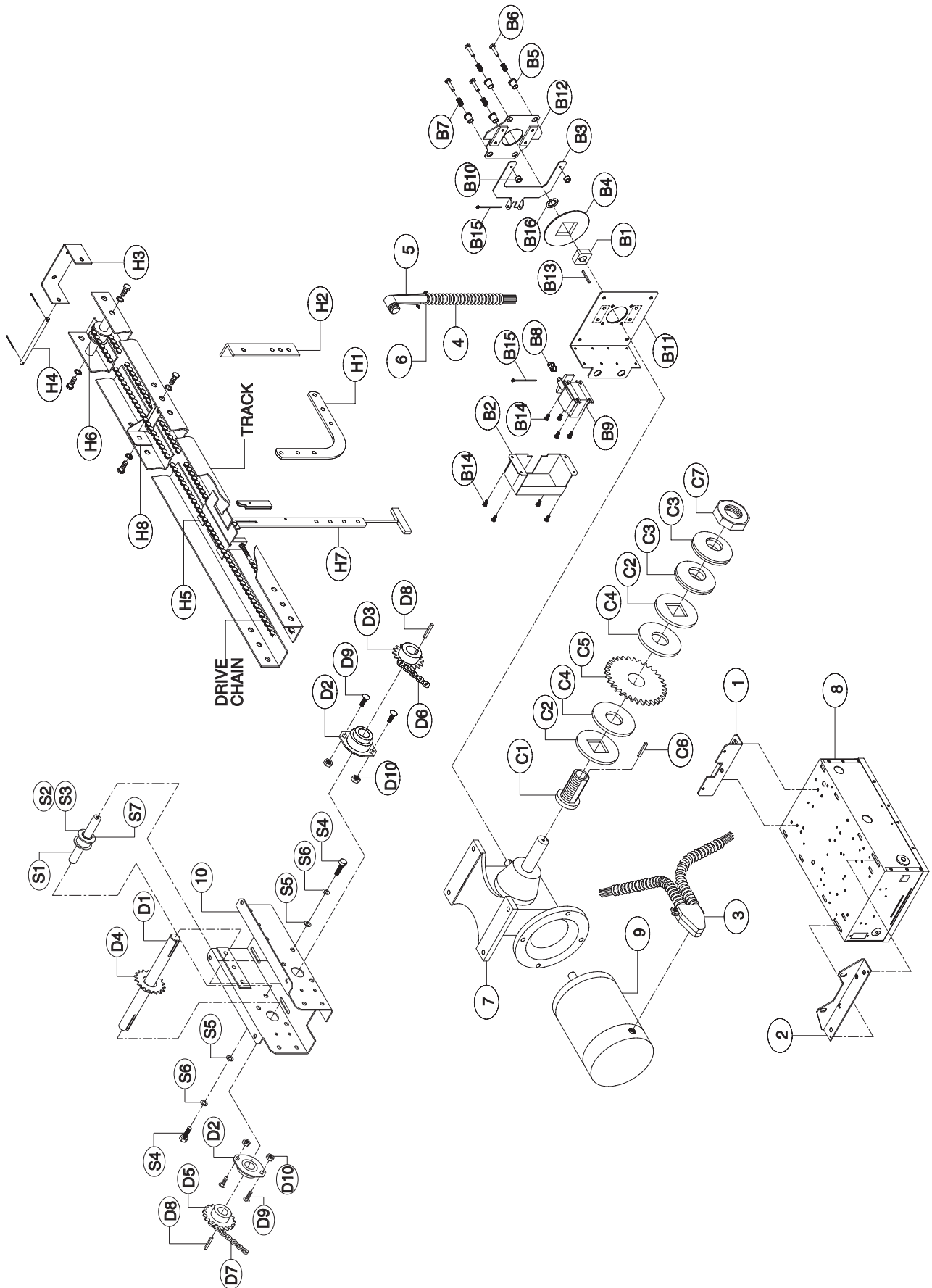

Refer to the parts lists below for replacement kits available for your operator. If optional modifications and/or accessories are included with your operator, certain components may be added or removed from these lists. Individual components of each kit may not be available. Please consult a parts and service representative regarding availability of individual components. Refer to page 19 for all repair part ordering information.

<b>BRAKE ASSEMBLY KITS</b>			
<b>KIT PART #</b>	<b>FOR</b>	<b>OPERATOR(S)</b>	
71-B120		115 Volt Models	
71-B240		230-460 Volt Models	
71-B575		575 Volt Models	
<b>ITEM</b>	<b>PART #</b>	<b>DESCRIPTION</b>	<b>QTY</b>
B1	07-10179	Brake Hub	1
B2	10-10187	Brake Solenoid Cover	1
B3	10-10190	Brake Release Lever	1
B4	10-10191	Brake Disc, Zinc Plated	1
B5	11-10192	Spring Cup for Brake Assembly	4
B6	11-10193	Brake Stud	4
B7	18-10194	Spring, Compression x .875" Long	4
B8	19-48001	Chain, #48 x 1 Pitch	1
B9	22-120	Brake Solenoid, 115V	1
	22-240	Brake Solenoid, 230-460V	1
	22-575	Brake Solenoid, 575V	1
B10	31-10186	Spacer, .20 I.D. x .31 Long	2
B11	75-10180	Brake Mounting Plate Assembly	1
B12	75-10184	Brake Pressure Plate Assembly	1
B13	80-9001	Feather Key	1
B14	82-WX10-08T	Screw, #10-32 x 1/2" Serrated Flange	8
B15	86-CP04-112	Cotter Pin, 1/8" x 1-3/4" Zinc Plate	2
B16	87-P-062	Push on Fastener, 5/8" Int. Star	1

<b>INDIVIDUAL PARTS</b>			
<b>ITEM</b>	<b>PART #</b>	<b>DESCRIPTION</b>	<b>QTY</b>
1	10-10446	MTG. Bracket, Elec Box-Brake	1
2	10-10447	MTG. Bracket, Elec Box-Reducer	1
3	27-10188	Double BX Connector	1
4	28-10218	Conduit, 3/8"	1
5	28-10219	Connector, 90 degree	1
6	28-10220	Bushing, Anti-Short	1
7	32-10540	Gear Reducer	1
8	See Page 24	Electrical Box Replacement Kit	1
9	See Page 24	Motor Replacement Kit	1
10	10-10536	Frame	1

<b>K72-12859 DRIVE SHAFT ASSEMBLY KIT</b>			
<b>ITEM</b>	<b>PART #</b>	<b>DESCRIPTION</b>	<b>QTY</b>
D1	11-10537	Drive Shaft	1
D2	12-12004	1" Ball Bearing	2
D3	15-40B19LGF	Sprocket, 40B19 x 1" Bore	1
D4	15-41B12LXX	Sprocket, 41B12 x 1" Bore	1
D5	15-48B18LGE	Sprocket, 48B18 x 1" Bore	1
D6	19-40047M	Drive Chain, #40 w/ Master Link	1
D7	19-48069M	Limit Chain, #48 w/ Master Link	1
D8	80-207-23	Key, 3/16" x 3/16" x 1-3/8"	2
D9	82-RN31-08	Carriage Bolt, 5/16-18 x 1/2"	4
D10	84-FN-31	Nut, 5/16-18 Serrated Flange	4

<b>K77-10201 HARDWARE KIT</b>			
<b>ITEM</b>	<b>PART #</b>	<b>DESCRIPTION</b>	<b>QTY</b>
H1	10-10203	Curved Arm	1
H2	10-10204	Door Bracket	1
H3	10-10205	Header Bracket	1
H4	11-10130	Header Pivot Pin	1
H5	75-10170	Slider Assembly	1
H6	75-10174	Front Idler Assembly	1
H7	75-10214	Straight Arm Assembly	1
H8	75-10259	Track Spacer Assembly	2

<b>K75-12858 TORQUE LIMITER ASSEMBLY KIT</b>			
<b>ITEM</b>	<b>PART #</b>	<b>DESCRIPTION</b>	<b>QTY</b>
C1	07-10534	Hub, Torque Limiter	1
C2	07-10535	Clutch Pressure Plate	2
C3	18-10539	Belleville Washer	4
C4	39-10541	Clutch Disc	2
C5	75-40A25	Sprocket Assy, 40A25	1
C6	80-207-19	Key, 1/4" x 1/4" x 1-1/2"	1
C7	84-JH-150	Hex Jam Nut, 1-1/2"-12	1

<b>K75-12870 STRAIGHT AND CURVED ARM ASSY</b>			
<b>ITEM</b>	<b>PART #</b>	<b>DESCRIPTION</b>	<b>QTY</b>
H1	10-10203	Curved Armblly	1
H7	75-10214	Straight Arm Assembly	1

<b>K72-18989 IDLER SHAFT ASSEMBLY KIT</b>			
<b>ITEM</b>	<b>PART #</b>	<b>DESCRIPTION</b>	<b>QTY</b>
S1	11-18948	IDLER SHAFT	1
S2	12-10172	BEARING	1
S3	17-10173	PULLEY	1
S4	82-HN38-12	HEX BOLT, 3/8-16" X 3/4" LONG	2
S5	85-FW-38	FLATWASHER, 3/8"	2
S6	85-LS-38	LOCKWASHER, 3/8"	2
S7	87-E-075	E-RING	2

<b>DOOR TRACK AND DRIVE CHAIN KITS</b>			
<b>DOOR HEIGHT</b>	<b>DOOR TRACK</b>		<b>#41 DOOR DRIVE CHAIN</b>
	<b>PART #</b>	<b>DESCRIPTION</b>	<b>PART #</b>
Doors to 8'	10-5808	Track, 11' Length	19-5112
Doors to 10'	10-5810	Track, 13' Length	19-5112
Doors to 12'	10-5812	Track, 15' Length	19-5112
Doors to 14'	10-5814	Track, 17' Length	19-5114
Doors to 16'	10-5816	Track, 19' Length	19-5116
Doors to 18'	10-5818	Track, 21' Length	19-5118
Doors to 20'	10-5820	Track, 23' Length	19-5120
Doors to 22'	10-5824	Track, 27'-6" Length	19-5124
Doors to 24'	10-5824	Track, 27'-6" Length	19-5124



# CONTROL CONNECTION DIAGRAM



**IMPORTANT NOTES:**

- The 3-Button Control Station provided must be connected for operation.
- ◆ If a STOP button is not used, a jumper must be placed between terminals 4 and 5.

