

USER'S GUIDE

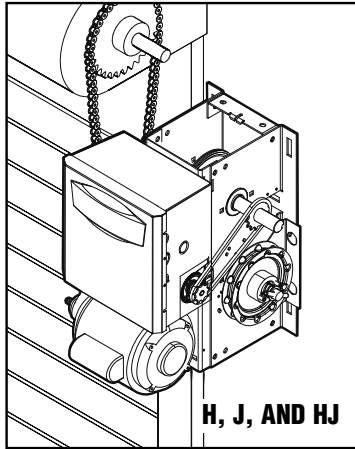

H, J, AND HJ

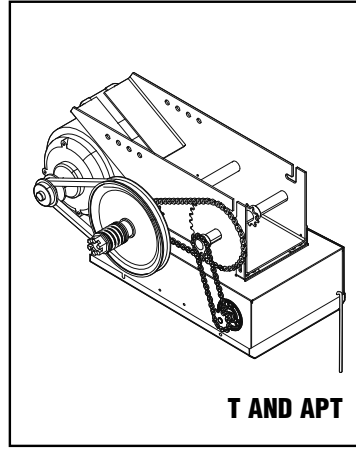

T AND APT

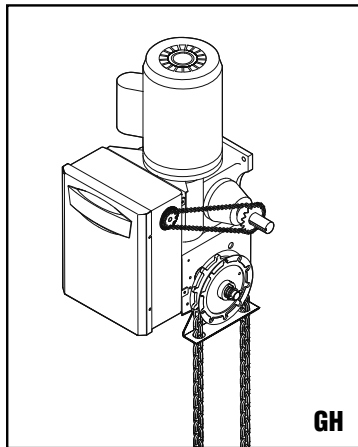
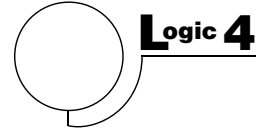

GH

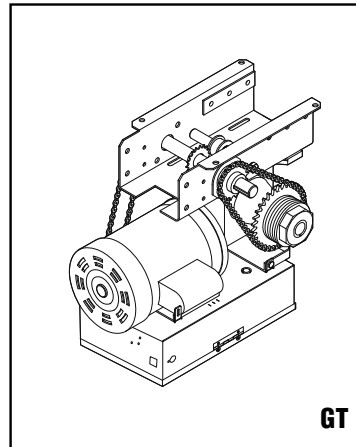

GT

THIS PRODUCT IS TO BE INSTALLED AND SERVICED BY A TRAINED DOOR SYSTEMS TECHNICIAN ONLY.

Operators are shipped in C2 operating mode.

Visit www.liftmaster.com to locate a professional installing dealer in your area.

2 YEAR WARRANTY

Serial # Box _____

Installation Date _____

CONTACT INFORMATION

THIS OPERATOR FEATURES THE ENHANCED



The Maintenance Alert System™ allows the installer to set an internal Maintenance Cycle Counter. The Logic 4 operator incorporates a self-diagnostic feature built into the (MAS) Maintenance Alert System LED. An LED on the 3-button station will signal when the set number of cycles/months is reached or when the operator requires immediate service.

NOT FOR RESIDENTIAL USE



**315MHz
Radio Receiver
Built on Board**

INTRODUCTION

Congratulations on purchasing a quality, LiftMaster Logic 4 Commercial Door Operator. Your new operator is capable of operating up to 12 cycles per hour or 50 cycles per day. It is equipped with a built in radio receiver that is compatible with our existing 315 MHz product line as well as a Timer-to-Close (TTC) feature that can be enabled when LiftMaster Commercial Protector System® is installed and aligned properly.

BASIC PROGRAMMING

INTRODUCTION TO PROGRAMMING

Many programmable functions require that a LiftMaster Entrapment Protection (LMEP) device be installed in order to function. Refer to the *Entrapment Protection* section.

LOGIC BOARD OVERVIEW

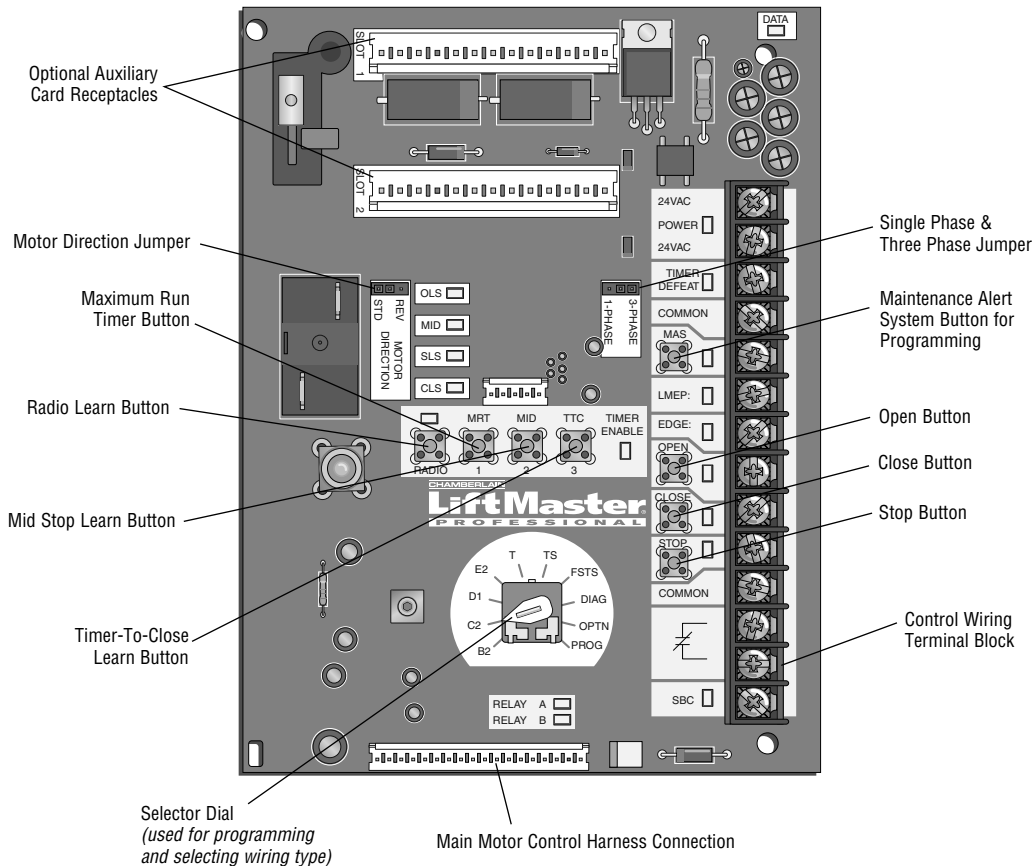

LOGIC BOARD LED OVERVIEW

NOTE: Before programming the logic board, set the operator's open and close limits. LEDs on the logic board are provided to assist setting the limits. As each limit is activated the corresponding LED will light up. The abbreviations are Open Limit Switch (OLS), Close Limit Switch (CLS) and Sensing Limit Switch (SLS). Refer to page 19 for limit switch adjustment instructions.

When power is applied to the operator, the following LED's will illuminate: STOP, CLOSE, OPEN, LMEP, 24Vac, RADIO, DATA, TIMER ENABLE, OLS MID, SLS, CLS, and MAS. Once the power up process is completed (approximately 2-3 seconds) only the appropriate LED's will continue to be lit (i.e., STOP, 24Vdc, limit LED(s) if limit(s) is activated).

NOTE: When the power up process is over, the MAS LED will blink a code indicating the version of firmware. If the selector dial is in the DIAG, OPTN, or PROG position, the MAS will not provide this code. After the code has been provided the MAS LED will go out.

LOGIC BOARD PUSH BUTTONS (OPEN, CLOSE, STOP)

Open, Close and Stop buttons are mounted directly on the logic board. Thus, making it easy to program as well as have door control at the electrical box.

Either the stop control or a jumper MUST be wired between terminals 4 and 5 for the on board push buttons to function.

BASIC PROGRAMMING

DETERMINE AND SET WIRING TYPE

Read the descriptions of the different wiring types to determine which setting will be correct for each application. Once the wiring type is determined, set the selector dial accordingly.

LIFTMASTER MONITORED ENTRAPMENT PROTECTION (LMEP) DEVICE IS REQUIRED

A LiftMaster Entrapment Protection (LMEP) device is **required** for the following wiring types.

- B2** Momentary contact to open, close and stop, plus wiring for sensing device to reverse and auxiliary devices to open and close with open override. Programmable mid stop available with this wiring type. **Compatible with 3-Button Station, 1-Button Station, 1 and 3-Button Remote Control.**

TS (TIMER SECURE)

This mode will attempt to close the door from any position except when fully closed, or when a safety input is present. The stop button will not disable the Timer-To-Close at any position. To disable the Timer-To-Close in this mode, installation of a defeat switch is required (see wiring diagram).

Momentary contact to open, close, and stop with open override and Timer-To-Close. Every device that causes door to open, including a reversing device, activates the Timer-To-Close. Auxiliary controls can be connected to open input to activate the Timer-To-Close. If the timer has been activated, the open button and radio control can recycle the timer. The Timer-To-Close will function from the programmable mid stop with this wiring type. **Compatible with 3-Button Station, 1-Button Station and 1 and 3-Button Remote Control.**

NOTE: A Programmable "Car Dealer Mode" available.

- T** Momentary contact to open, close, and stop, with open override and Timer-To-Close. Every device that causes the door to open, except any safety edge input device, activates the Timer-To-Close. Auxiliary controls can be connected to open input to activate the Timer-To-Close. If the Timer-To-Close has been activated, the open button and radio control can recycle the timer. The stop button will deactivate the timer until the next command input. The Timer-To-Close will function from the programmable mid stop with this wiring type. **Compatible with 3-Button Station, 1-Button Station and 1 and 3-Button Remote Control.**

NOTE: Programmable "Car Dealer Mode" available.

- FSTS** Momentary button contact for open, close and stop programming. User set mid stop. User set Timer-To-Close. The single button station opens the door to the full open limit bypassing the mid stop and activates the Timer-To-Close, putting the operator in TS mode until the door reaches the down limit, or is stopped in travel. At which time the operator enters the B2 mode.

Compatible with 3-Button Station, 1-Button Station, 1 and 3-Button Remote Control. A 1-Button remote control in FSTS mode will open only with the Timer-To-Close, bypassing a programmed mid stop. The Timer-To-Close will reset and reverse when closing.

LIFTMASTER MONITORED ENTRAPMENT PROTECTION (LMEP) DEVICE IS RECOMMENDED

A LiftMaster Entrapment Protection (LMEP) device is recommended for the following wiring types.

- C2** Momentary contact to open and stop with constant pressure to close, open override plus wiring for sensing device to reverse. Programmable mid stop available with this wiring type. **Compatible with 3-Button Station and 1-Button Station.**
- E2** Momentary contact to open with override and constant pressure to close. Release of close button will cause door to reverse (roll-back feature) plus wiring for sensing device to reverse. **Compatible with 3-Button Station.**
- D1** Constant pressure to open and close with wiring for sensing device to stop. **Compatible with 2 or 3-Button Station.**

SELECTOR DIAL

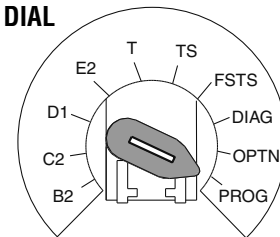

IMPORTANT NOTES:

- External interlocks may be used with all functional modes.
- Auxiliary devices are any devices that have only dry contacts.
Examples: photocell, loop detector, pneumatic or electrical treadles, radio controls, one button stations, pull cords, etc.
- Open override means that the door may be reversed while closing by activating an opening device without the need to use the stop button first.
- When the door is in a stopped position other than fully closed, and a safety input is activated (LMEP or EDGE), the Restricted Close (RC) feature will allow a close command when the close button is pressed and held. The operator will begin closing after 5 seconds. If the close button is released the door will stop.
When in E2 mode, the door will move to the fully open position.

BASIC PROGRAMMING

⚠ WARNING

To prevent possible SEVERE INJURY or DEATH:

- Install a LiftMaster Monitored Entrapment Protection (LMEP) device.
- NEVER permit children to operate or play with door control push buttons or remote controls.
- Activate door ONLY when it can be seen clearly, is properly adjusted and there are no obstructions to door travel.
- ALWAYS keep door in sight until completely closed. NEVER permit anyone to cross the path of closing door.

REMOTE CONTROLS

Built in 3-channel, 315 MHz radio receiver allows you to add as many as 23 Security+® remotes or dip switch remote controls.

NOTE: The following programming requires a LiftMaster Monitored Entrapment Protection (LMEP) device.

SINGLE BUTTON REMOTE CONTROL

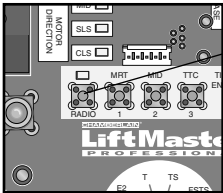
- 

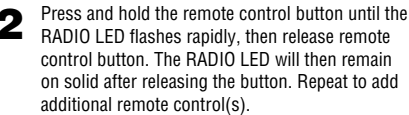
Press and release the RADIO button (RADIO LED will light).
 - 

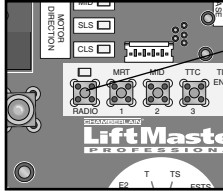
Press and hold the remote control button until the RADIO LED flashes rapidly, then release remote control button. The RADIO LED will then remain on solid after releasing the button. Repeat to add additional remote control(s).
 - 

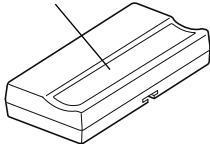
Press and release the RADIO button to complete the programming. The programming mode is exited if no activity is performed within 30 seconds.
- 

3-BUTTON REMOTE CONTROL TO OPERATE AS A WIRELESS 3-BUTTON CONTROL STATION

NOTE: The feature will use 3 of the 23 memory channels in the operator.

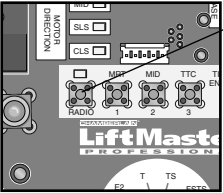
- 

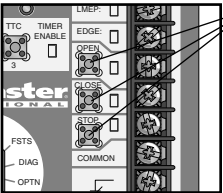
Press and release the RADIO button on the logic board (the Radio LED will light).
 - 

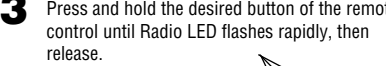
Press and release the desired button on the logic board (OPEN, CLOSE or STOP). The Radio LED will flash and then stay on solid.
 - 

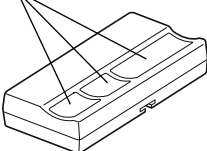
Press and hold the desired button of the remote control until Radio LED flashes rapidly, then release.
- 

Repeat steps 1 through 3 to program additional buttons.

TO ERASE ALL REMOTE CONTROLS

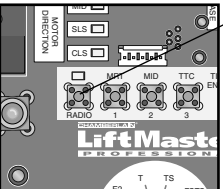
- 

Press and hold the RADIO button on the logic board until the RADIO LED flashes rapidly (approximately 5 seconds). All remote controls will be erased.

BASIC PROGRAMMING

⚠ WARNING

To prevent possible SEVERE INJURY or DEATH:

- Install a LiftMaster Monitored Entrapment Protection (LMEP) device.
- NEVER permit children to operate or play with door control push buttons or remote controls.
- Activate door ONLY when it can be seen clearly, is properly adjusted and there are no obstructions to door travel.
- ALWAYS keep door in sight until completely closed. NEVER permit anyone to cross path of closing door.

TIMER-TO-CLOSE

Feature: Timer automatically closes door after preset time. All safety devices must be unobstructed.

Benefit: The door will automatically close after preset amount of time. Great for apartment buildings, fire stations and other applications where the end user wants the door to close automatically after a specified amount of time.

Requirements: Must have at least one LiftMaster Monitored Entrapment Protection (LMEP) device installed (refer to page 20). Wiring type must be set to TS, T or FSTS.

TO PROGRAM MANUALLY (METHOD 1):

1. Close the door.
2. Turn the selector dial to PROGRAM.
3. Press and release the TIMER button on the logic board.
4. Press and release the STOP button to clear the timer.
5. Press and release the OPEN button for every second the operator should wait before attempting to close the door. Press and release the CLOSE button for every 15 seconds the operator should wait before closing the door.

6. Press and release the TIMER button to complete programming. The OPEN/CLOSE button LEDs will flash to confirm the timer setting. The OPEN LED will flash once for every second programmed and the CLOSE LED will flash once for every 15 seconds programmed.
7. Turn the selector dial to desired timer wiring type (TS, T or FSTS).

Example: To close the door after 70 seconds. Turn selector dial to PROGRAM, press and release the TIMER button, press and release the STOP button to clear the timer, press and release the CLOSE button four times for 60 seconds and press and release the OPEN button 10 times for 10 seconds. Press the TIMER button to finish programming the timer. Turn selector dial to desired timer wiring type. (TS, T, FSTS).

SELECTOR DIAL

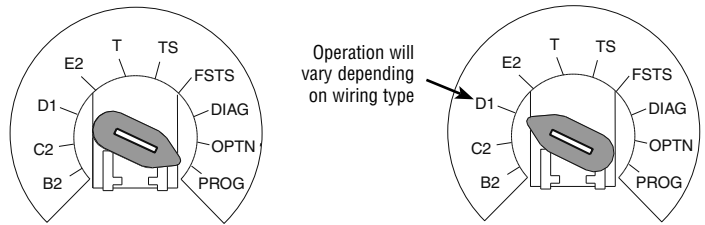

PROGRAM TIMER-TO-CLOSE BY EXAMPLE (Method 2):

TO PROGRAM:

1. Close the door.
2. Turn the selector dial to PROGRAM.
3. Press and hold TIMER button for 5 seconds until OPEN and OLS flashes then release.
4. Press and release the OPEN button and wait for the door to reach full open or mid stop position.
5. Wait for desired amount of time to pass. (An internal stop watch starts counting when the door stops moving.)
6. Press and release the TIMER button, CLOSE button or STOP button to stop the timer. (TIMER SET LED will turn on.)
7. Turn the selector dial to the desired wiring type (T, TS, FSTS).

NOTE: To read back the Timer-To-Close setting, turn the selector dial to DIAGNOSTIC and press the TIMER button. The OPEN LED will flash once for every second programmed and the CLOSE LED will flash once for every 15 seconds programmed.

To deactivate the timer from the open position press the STOP button. The timer will be reactivated on the next operation command. To deactivate the timer for more than one cycle, attach a switch to 11 and 12 (Common and Timer Defeat).

Reminders: FSTS wiring mode allows the Timer-To-Close to be activated by the Single Button Control (terminal 1) only. T wiring mode allows the door to attempt to close only one time for safety purposes.

SELECTOR DIAL

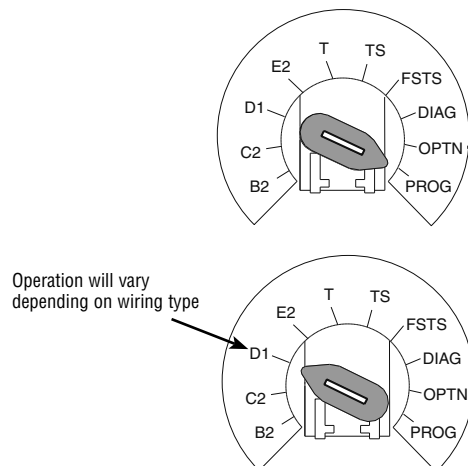

MANUAL RELEASE

WARNING

To prevent possible SERIOUS INJURY or DEATH from a falling door or arm:

- DO NOT stand under the door arm when pulling the emergency release.
- If possible, use emergency release handle to disengage trolley ONLY when door is CLOSED. Weak or broken springs or unbalanced door could result in an open door falling rapidly and/or unexpectedly.
- NEVER use emergency release handle unless doorway is clear of persons and obstructions.

EMERGENCY DISCONNECT SYSTEM MODEL GT AND T

TO DISCONNECT DOOR FROM OPERATOR

The door should be in the fully closed position if possible.

- 1** Pull emergency release handle straight down. Emergency disconnect will open.

TO RECONNECT DOOR ARM TO TROLLEY

- 2** Lift free end of door arm to trolley. Pull emergency release handle to allow arm to engage roll pin. Release handle. Emergency disconnect will close.

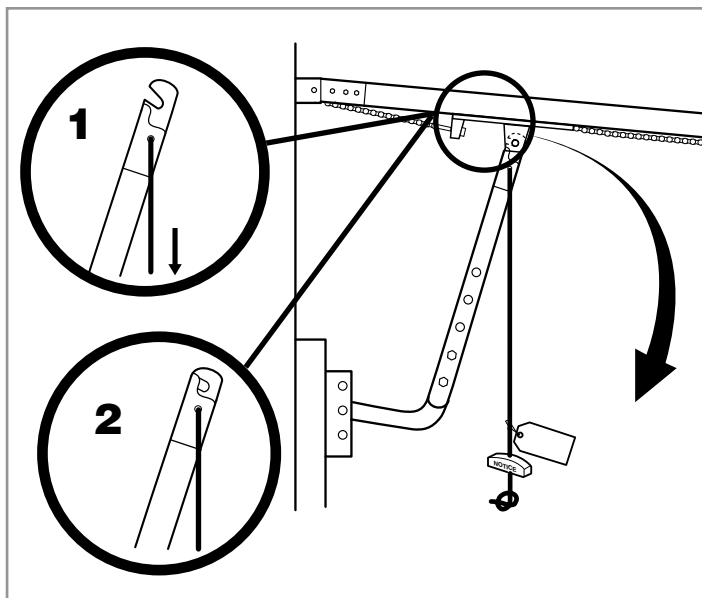

EMERGENCY DISCONNECT SYSTEM MODEL APT

TO DISCONNECT DOOR FROM OPERATOR

The door should be in the fully closed position if possible.

- 1** Pull down on the emergency release handle and raise or lower the door manually.

TO RECONNECT DOOR ARM TO TROLLEY

- 2** The trolley will reconnect on the next UP or DOWN operation, either manually or by using the door control or remote.

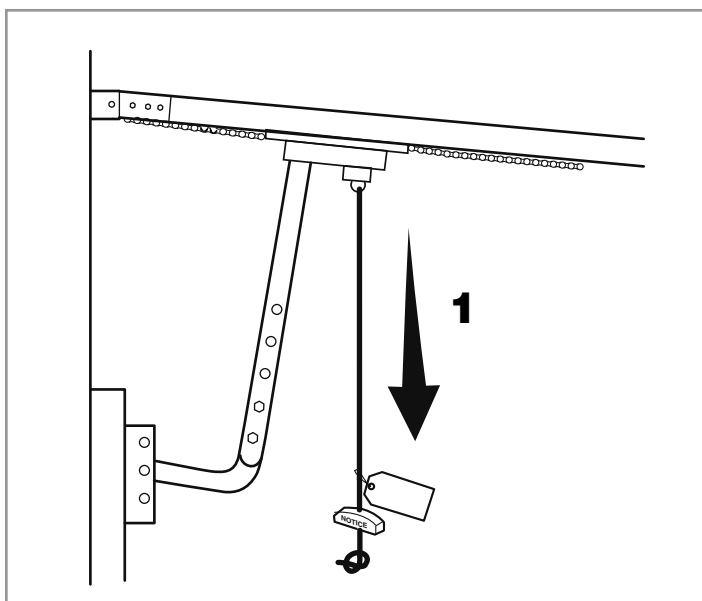

MANUAL RELEASE

EMERGENCY DISCONNECT SYSTEM MODEL H, GH, J, AND HJ

This operator has provisions for manually operating the door in case of emergency or power failure. Refer to the appropriate instructions below for your model operator.

MODEL H AND GH

These operators are equipped with a manual hoist. An electrical interlock will disable the electrical controls when the hoist is used. To operate the hoist:

- 1** Pull the disconnect chain (sash chain) to engage the hoist mechanism. The disconnect chain may be locked in position by slipping the end through the keyhole of the chain keeper mounted on the wall.
- 2** Operate the door in the desired direction by pulling on one side or the other of the continuous loop hoist chain.
- 3** The disconnect chain must be released from the chain keeper before the door will operate again electrically.

MODEL J

This operator has a floor level disconnect chain to disconnect the door from the door operator.

- 1** To disengage, pull the disconnect chain (sash chain) and secure in the disengaged position by slipping the end through the keyhole bracket mounted on the wall.
- 2** The door may now be pushed up or pulled down manually.
- 3** Release the disconnect chain to operate the door again electrically.

MODEL HJ

This operator includes both a floor level disconnect chain (sash chain) to disconnect the door from the door operator and a disconnect chain with manual hoist to electrically disable the operator controls.

- 1** Pull the disconnect chain to engage the hoist mechanism. The disconnect chain may be locked in position by slipping the end through the keyhole of the chain keeper mounted on the wall.
- 2** To disengage, pull the disconnect chain and secure in the disengaged position by slipping the end through the keyhole bracket mounted on the wall.
- 3** Operate the door in the desired direction by pulling on one side or the other of the continuous loop hoist chain.
- 4** Release the disconnect chain to operate the door again electrically.

CAUTION

- To prevent possible **SERIOUS INJURY** from a moving chain:
- **DISCONNECT** electric power to the operator **BEFORE** manually operating your door.
 - If possible, use emergency disconnect **ONLY** when door is **CLOSED**. Weak or broken springs or unbalanced door could result in an open door falling rapidly and/or unexpectedly.
 - **NEVER** use emergency disconnect unless doorway is clear of persons and obstructions.

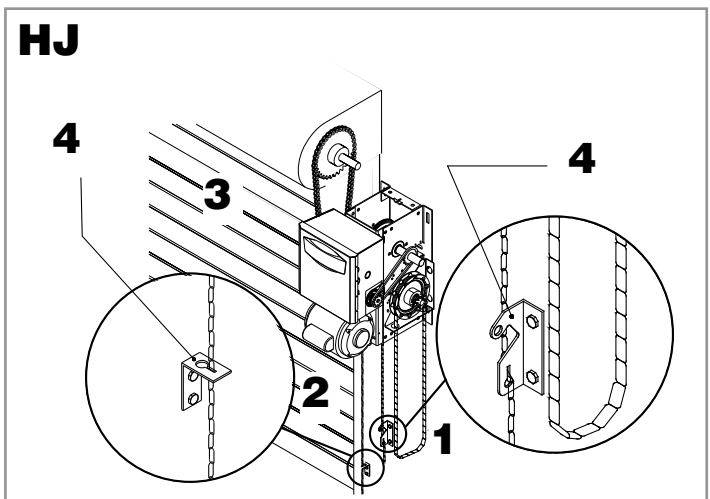
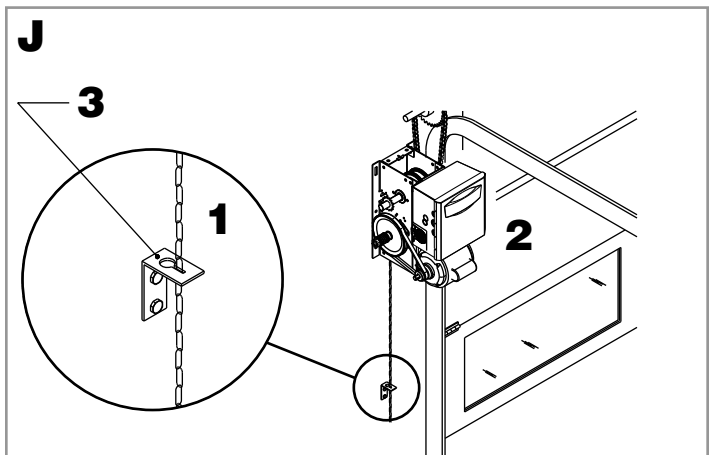
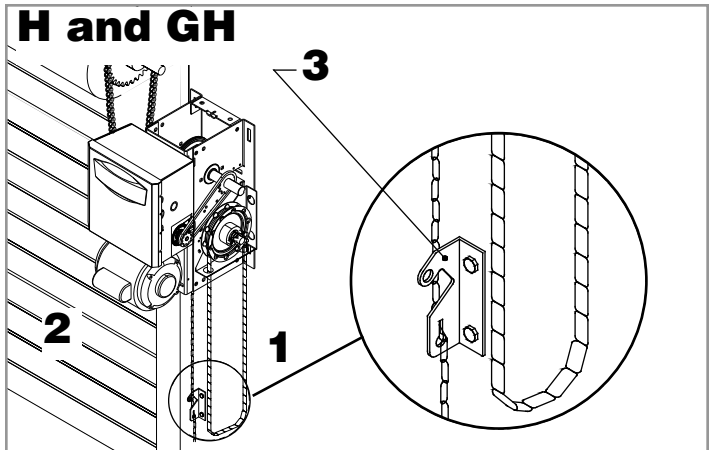

TESTING

Apply power to the operator.

When power is applied to the operator, the following LED's will illuminate: STOP, CLOSE, OPEN, LMEP, 24Vac, RADIO, DATA, TIMER ENABLE, OLS MID, SLS, CLS, and MAS. Once the power up process is completed (approximately 2-3 seconds) only the appropriate LED's will continue to be lit:

- Between limits: 24Vac and STOP
- Fully closed position: 24Vac, STOP, CLS and SLS
- Fully opened position: 24Vac, STOP and OLS

Additional LED's will light when device(s) are activated.

NOTE: When the power up process is over, the MAS LED will blink a code indicating the version of firmware. If the selector dial is in the DIAG, OPTN, or PROG position, the MAS will not provide this code. After the code has been provided the MAS LED will go out.

ALIGN THE PHOTOELECTRIC SENSORS

1. After power is connected to the operator, the green indicator lights in both the sending and receiving sensors will glow steadily if wiring connections and alignment are correct.
2. If the receiving sensor indicator light is not glowing steadily (and the invisible light beam path is not obstructed), alignment is required:
 - Loosen the *receiving sensor* wing nut to allow slight rotation of the sensor. Adjust sensor vertically and/or horizontally until the green indicator light glows steadily.
 - When the indicator lights are glowing in both sensors, tighten the receiving sensor wing nut.

TEST THE PHOTOELECTRIC SENSORS

1. Open the door.
2. Place an obstruction in the path of the photoelectric sensors. The LMEP LED will blink on the logic board and the receiving eye LED will turn off.
3. Press and hold the CLOSE button. The door should not close if photoelectric sensors are installed.
4. Remove the obstruction.
5. Press and hold the CLOSE button. Door should close. If door did not reverse from obstruction, check photoelectric sensors.

IMPORTANT NOTES:

- Do not leave power to the operator on unless all safety and entrapment protection devices have been tested and are working properly.
- Be sure you have read and understand all safety instructions included in this manual.
- Be sure the owner or person(s) responsible for operation of the door have read and understand the safety instructions, know how to electrically operate the door in a safe manner and how to manually disconnect the door from the operator.

WARNING

To avoid SERIOUS personal INJURY or DEATH:

- Disconnect electric power BEFORE performing ANY adjustments or maintenance.
- ALL maintenance MUST be performed by a trained door systems technician.

TEST 3-BUTTON CONTROL STATION

1. Press OPEN button. (The door should move in the open direction.)
2. Press STOP button. (The door should stop.)
3. Press and hold the CLOSE button. (The door should move in the close direction.)
4. Release CLOSE button. Door should stop if in C2 or D1 mode. Door will reverse to full open position in E2 mode. The door should continue closing in all other modes.
5. Press STOP button. (The door should stop.)

TEST LIMIT ADJUSTMENT

1. Press OPEN button. (The door should open.)
2. Allow the door to fully open.
3. Press and hold the CLOSE button. (The door should close.)
4. Allow the door to fully close.
5. If the limits are not set properly, remove power and adjust limits (refer to Limit Adjustment section).

TROUBLESHOOTING

To locate a dealer in your area visit us online at www.liftmaster.com

CONDITION	POSSIBLE CAUSE	FIX
OPERATOR WILL NOT RESPOND TO ANY COMMANDS	No power	➤ Check circuit breaker.
	Accessory failure	➤ Verify photoelectric sensors are aligned.
	Possible component failure	➤ Contact your installing dealer.
OPERATOR MAKES NOISE BUT DOOR DOES NOT MOVE	Operator requires adjustment	➤ Contact your installing dealer.
DOOR DRIFTS AFTER OPERATOR STOPS	Operator or door requires adjustment	➤ Contact your installing dealer.
DOOR OPENS/ CLOSES TOO FAR	Operator requires adjustment	➤ Contact your installing dealer.
DOOR REVERSES UNEXPECTEDLY	Entrapment protection device activated	➤ Verify photoelectric sensors are aligned. If photoelectric sensors are aligned and operator still does not operate properly, contact your installing dealer.
<i>RADIO FUNCTIONALITY</i>		
NO RESPONSE	Remote control is not programmed	➤ See PROGRAMMING REMOTE CONTROLS section.
	Low battery	➤ Replace battery.
REMOTE CANNOT BE PROGRAMMED	Low battery	➤ Replace battery.
POOR RANGE	Low battery in remote	➤ Replace battery.
	Possible radio interference	➤ Contact your installing dealer.

MAINTENANCE SCHEDULE

WARNING

To avoid **SERIOUS** personal **INJURY** or **DEATH**:

- Disconnect electric power **BEFORE** performing ANY adjustments or maintenance.
- **ALL** maintenance **MUST** be performed by a trained door systems technician.

Every 3 months or 5,000 cycles repeat all tests in the Testing section.

Call a trained door systems technician. To locate a dealer in your area visit us online at www.liftmaster.com.

The operator should be serviced at the following intervals:

- Every 3 months or 5,000 cycles
- Every 6 months or 10,000 cycles
- Every 12 months or 20,000 cycles

ACCESSORIES

REMOTE CONTROLS 315MHz

371LM  **1-Button SECURITY+® Remote Control:**
Includes visor clip.

373LM  **3-Button SECURITY+® Remote Control:**
Includes visor clip.

333LM  **3-Button Tri-Colored Dip Switch Remote Control:**
Includes visor clip.

CONTROL STATIONS

02-101  **1-Button Control Station:**
Steel enclosure.

02-102  **2-Button Control Station:**
Steel enclosure.

02-103L  **3-Button Control Station:**
Steel enclosure with Maintenance Alert System.

02-110  **Key Control Station:**
Indoor flush mount, NEMA 1 with Stop button.

MOUNTING BRACKETS

10-12360  Heavy gauge steel bracket for vertical or horizontal mount on either front or top of coil on a rolling door. Has a variety of mounting hole patterns compatible with many OEM manufacturers. May be welded. For use with J, H, DJ, and DH operators.

08-9098  Cast iron bracket to mount J, H, DH, DJ, and GH side mount operators on end bracket of a rolling door or grill. For vertical or horizontal mount on either front or top of coil.

08-9098EZ  Same as 08-9098, but with adapter plate to hold mounting bolt holes in place for ease of use.

1A4324  Heavy gauge steel bracket for vertical or horizontal mount on either front or top of coil on a rolling door. May be welded. For use with J, H, DJ, and DH operators.

1A4324EZ  Same as 1A4324, but with adapter plate to hold mounting bolt holes in place for ease of use.

MISCELLANEOUS

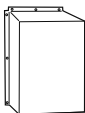
1A3982  **Operator Cover:**
For use with wall-mounted J, H, GH, DH or DJ operators. Measures 31" x 19" x 18" (L x W x D). Assembly required. Recommended for damp environments where direct spray is present. Required when the operator is installed less than 8 feet above the floor.

86LM (15')
86LMT (25')  **Antenna Extension Kit:**
The antenna extension kit can be used with EXT-ANT for maximum radio receiver range.

ENTRAPMENT PROTECTION DEVICES

MONITORED

CPS-UN4  **Commercial Protector System®:**
Provides protection on doors up to 45' wide. NEMA-4 rated.

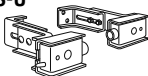
CPS-U  **Commercial Protector System®:**
Provides protection on doors up to 30' wide.

CPS3  **Option Logic Board:**
For use when more than one set of photoelectric eyes are required.

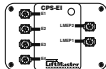
CPS-EI  **Monitored Safety Edge Interface:**
For use with the approved 4-wire safety edge (see below).

65ME1234 **Miller ME123 4-Wire Monitored Safety Edge:**
For sectional or rolling doors.

65ME110 **Miller ME110 4-Wire Monitored Safety Edge:**
For rolling grilles and counter shutters.

NON-MONITORED

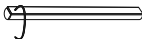
65-8202  **Vehicle Detection System:**
Pneumatic Sensing Edge Kit with exterior air switch, 2-wire coil cord and 14' air hose.

65-5202  **Vehicle Detection System:**
Pneumatic Sensing Edge Kit with exterior air switch, 2-wire take-up reel (20' extended) and 14' air hose.

TLSCARD **Timer Light Status Card:**
The TLS option card provides special functionality to activate and flash auxiliary devices such as lights, bells, and horns/strobes at various door positions, and to provide special timer functions.

AUXCARD **Auxiliary Contact Card:**
The Auxiliary Contact option card has both Normally-Open and Normally-Closed contacts that actuate when the door is idle, opening, or closing.

MOUNTING CHANNELS

65ME123C **U-Shaped Mounting Channel:**
For 65ME1234 edge when installed on sectional doors.

65ME123C1 **T-Shaped Mounting Channel:**
For 65ME1234 edge when installed on rolling doors. Fits between L-shaped angles used to construct a bottom bar on rolling doors.

65ME123CA3 **L-Shaped Mounting Channel:**
For 65ME1234 edge when installed on sectional doors.

CHAIN TENSIONERS For Jackshaft Type Operators

71-6023 For 1" shafts. Recommended to properly tension drive chain between operator shaft and door shaft.

71-6125 Same as 71-6023, but for 1-1/4" shafts.

